

Intermediate Radio Amateur Course

Cambridge and District Amateur
Radio Club (CDARC)

Acknowledgements

Members of

*The Cambridge & District Amateur Radio Club
(CDARC)*

who have contributed to this Intermediate Licence Course and associated learning material with helpful suggestions, practical expertise and constructive comment.

Recommended Reading

This course is structured around:

The Intermediate Licence Syllabus (Published by the RCF and obtainable as a pdf download from the internet.)

The RSGB book “Intermediate Licence: *Building on the Foundation*” (ISBN 9781 – 9050 – 8650 – 4)

You should obtain a copy of both these texts to help you with your own studies which this CD ROM supports.

NB! You will need to invest at least 20 hours of study before taking the examination. You must already hold a Foundation Licence.

Purpose Of These Slides

These slides are a supplement to the RSGB book:

“Intermediate Licence – *Building on the Foundation*”

and provide a further explanation to some of the topics.

Jargon

You will have already passed your Foundation Licence and have had some operating experience.

However there will probably be some terms, phrases and abbreviations that you have yet to come across.

If we use any terms in this course with which you are not familiar please stop us and ask for an explanation in plain English!

Course Topics

- Amateur Radio
- Licensing Conditions
- Technical Basics
- Transmitters and Receivers
- Feeders and Antennas
- Propagation
- EMC
- Operating Practices and Procedures
- Safety
- Construction

Topic 1: Amateur Radio

Topic 1 (Amateur Radio): Contents

- Nature of Amateur Radio
- Types of Amateur Licence
- UK Callsigns
- Regional Secondary Locators
- Modified Callsigns
- Assembling the Callsign
- Operating Outside of the “Home Region”

Nature of Amateur Radio

From your Foundation Course you will recall that Amateur Radio is about:

- self-training in radio communication;
- experimentation;
- community service;
- not commercial or for profit.

Types of Amateur Licence

In the UK there are three classes (types) of Amateur Radio Licence:

- 1.The Foundation Licence;
- 2.The Intermediate Licence;
3. The Full Licence.

UK Callsigns

The class of UK licence is identified through the callsign prefix.

- Foundation: M3 or M6 prefix to the callsign
- Intermediate: 2 prefix.
- Full: M1, M5, M0, G prefix.

Regional Secondary Locators

An additional letter after the prefix in a UK callsign also indicates the Region within the UK from whence the transmission originates.

- M (Scotland) W (Wales)
- I (Northern Ireland) J (Jersey)
- D (Isle of Man) U (Guernsey)

(There is no Regional Secondary Locator for England in either the Foundation or Full Licence. Exceptionally, however, an Intermediate Callsign does use the letter E for England.)

Modified Callsigns

The basic callsign (Letter or Number) is modified to reflect the actual geographical location of the station within the UK when transmitting. The basic format of a callsign is:

$M\Delta nLLL$ or $G\Delta nLLL$ or $2\Delta\emptyset LLL$

Where:

Δ is a space for the modifying letter which identifies the UK Region;

n is the single digit number identifying the class of licence;

LLL are up to three letters forming the suffix.

Assembling The Callsign: (M & G Callsigns)

Let's consider an M callsign for a full licence holder – M0DCV.

Because the registered station address is in England there is no letter allocated to define this Region. Hence ofcom issued the callsign as M0DCV.

If, however, the registered station address was in Scotland ofcom would have still issued the basic callsign M0DCV but with an additional letter “M” in the space after the first M to identify the Region as Scotland. ie. MM0DCV.

The same protocol applies to G callsigns.

The important point is that M0DCV and MM0DCV refer to the same person (licence holder).

Similarly if the registered address were in Wales the callsign becomes MW0DCV, Northern Ireland MI0DCV etc.

Assembling The Callsign: 2 Series Callsigns

Intermediate licence callsigns are a little different from those in the M & G series. Here the letter E is used to indicate the English Region.

So intermediate callsigns are allocated as:

2E0LLL	England
2M0LLL	Scotland
2I0LLL	Northern Ireland
2W0LLL	Wales
2D0LLL	Isle of Man
2U0LLL	Guernsey
2J0LLL	Jersey

Operation Outside Of The Home Region

If you operate outside of your “Home Region” then you need to modify your callsign to reflect this geographical change. (For example your registered station address is in England and you go on holiday to Scotland and operate your radio from there.)

M and G callsigns change to MM or GM

eg. M0DCV becomes MM0DCV/P; G8VCN becomes GM8VCN/P etc

2E0LLL would change to 2M0LLL/P

Remember that /P; /A; /M; /MM have the same meaning as you learnt in the Foundation Course. Only full UK Licence holders may transmit /MM (Maritime Mobile). You may not transmit from an aircraft whatever class of licence you hold.

Topic 2: Licensing Conditions

Topic 2 (Licence Conditions): Contents

- Operators
- Messages
- Location and Identification
- Unattended Operation
- Log Keeping
- Apparatus
- Licensee's Details and Revocation of the Licence
- Licence Schedule

Operators

As an Intermediate Licence Holder you may:

1. Operate the Radio Equipment of any other licensed UK amateur under that person's direct supervision using the supervisor's callsign and obeying the terms of the supervisor's licence.
2. With permission use another amateur's Radio Equipment unsupervised but using the callsign of his or her own license.

(Radio Equipment (in initial capitals) is a defined licence term meaning the equipment used and identified by the operator's callsign. If a visiting amateur uses the radio equipment with his or her own callsign it is his/her Radio Equipment)

Commercial Gain

You may not use the Radio Equipment for business or advertising purposes.

Messages: (User Services)

1. You may pass messages on behalf of the User Services.
2. You may permit a member of the User Services to use the Radio Equipment to send messages.

(The User Services comprise: Fire, Police, Ambulance, Coastguard, Local Government etc.)

Location and Identification

You must transmit the callsign printed on the licence when:

1. Sending CQ calls;
2. When establishing communication;
3. Every 15 minutes during long periods of transmission;
4. If you change frequency.

Main Station Address

The Main Station Address is shown on the license.

1. The Alternative Address (/A) is: A post-coded address.
2. A Temporary Location (/P) is: A field, lay-by, hill top etc.
3. Mobile (/M) is: On foot, in a car, on a canal boat, lake etc.

Operation From Tidal Waters And Aircraft

1. You are not permitted to operate from the seaward side of the low-water line as marked on an official chart.
(ie. You may not operate /MM)
2. You are not permitted to operate from an aircraft.

Operation Outside Of The UK

1. Other Administrations (Foreign Countries) do not routinely recognise the UK Intermediate Licence.
2. Other Administrations may only recognise the Full UK Licence in any reciprocal agreement.

Unattended Operation

You may conduct unattended operation:

1. Of a beacon;
2. For the purposes of direction finding competitions;
3. For the remote control of the main station;
4. For digital communications.

Unattended Operation: Power

Any remote control link must:

1. Be by radio in an amateur band;
2. Be limited to a maximum transmit power of 500mW.

Unattended Operation: Use By Others

Unattended operation does not provide for general use by other amateurs.

Log Keeping

An authorised ofcom official may require the licence holder to keep a log of all transmissions made over a specified period of time.

(The license does nor require you to keep a log in the normal course of events. However it is the “professional” (!) way to run your amateur station. It is a wise procedure to adopt.)

Apparatus: Interference And Tests

1. Transmissions from the station must not cause undue interference to other radio users.
2. You (The licensee) must reduce any emissions causing interference to the satisfaction of a person authorised by ofcom.
3. You must carry out tests from time to time to ensure that your station is not causing undue interference.

Licensee's Details and Revocation

The licensee must:

1. Inform ofcom immediately if there is any change in the Licensee's name or registered address;
2. Confirm the details shown on the licence at least once every 5 years;
3. Understand that ofcom can revoke the licence for any breach in the licence conditions or non confirmation of the licence conditions.

Licence Schedule

HF Bands: You must be able to apply the schedule to the Intermediate License.

VHF Bands: You will be given a copy of the schedule for use during the exams.

Topic 3: Technical Basics

Topic 3: (Technical Basics) Contents

- Units of Measurement and Abbreviations
- Multiple and Sub-Multiple Prefixes
- Simple Circuit Theory
- Primary and Secondary Cells
- Capacitors
- Inductors
- Tuned Circuits
- Transformers
- Diodes and Transistors
- Circuit Symbols
- Measurements.

Units and Abbreviations

<u>Topic</u>	<u>Unit</u>	<u>Abbreviations</u>
Potential Difference	Volts	V
Current	Ampère	I, i, A
Power	Watts	P, W
Resistance	Ohms	Ω
Capacitance	Farads	F
Inductance	Henry	L
Frequency	Hertz	Hz

Multiple and Sub-Multiple Prefixes

In general in radio and electrical work the basic unit is often either too large or too small to be used directly. This can lead to either very big or very small numbers having to be used in calculations. (ie numbers containing lots of zeros before or after the decimal point.)

To avoid this we use multipliers and sub-multipliers to “soak-up” the zeros.

There is an accepted convention for these prefixes . This is that they are in powers of 10^3 ie multiples of 1000.

Common Prefixes

Prefix	Multiplier	Power of Ten
pico (p)	0.000 000 000 001	10E-12 (10 ⁻¹²)
nano (n)	0.000 000 001	10E-9
Micro (μ)	0.000 001	10E-6
milli (m)	0.001	10E-3
kilo (k)	1000	10E3 (10 ³)
Mega (M)	1 000 000	10E6
Giga (G)	1 000 000 000	10E9

Note: pico, nano, micro, milli, kilo, are always written in lower case. Mega and Giga are always written with an initial capital letter.

Non-Standard Prefixes

This will not be examined. However for completeness these appear below.

centi-	(c)	x100	10E2
deci-	(d)	x10	10E1
hecto-	(h)	x10,000	10E4

Examples:

Centigrade, centimetre;

Decibel;

Hectare.

These are based on multiples other than 10E3 but they are in common use.

Simple Circuit Theory: Flow Of Current In A Conductor.

In a conductor the flow of current is due to the motion of electrons down a potential gradient.

In a conductor the metallic crystal lattice contains free electrons which can move easily through the lattice when a potential gradient (potential difference) exists across the conductor.

Conductor: Random Electron Motions

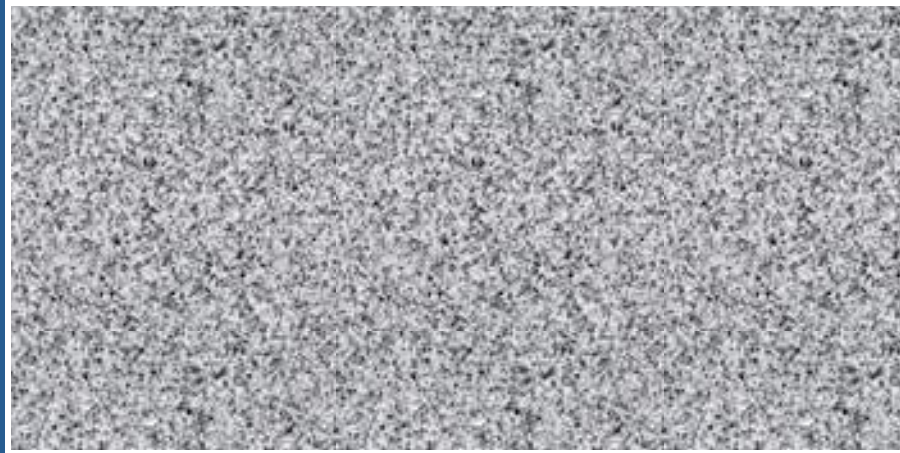

CONDUCTOR:

The conductor has lots of free electrons within the atomic lattice. These will move easily under an applied voltage and constitute a current.

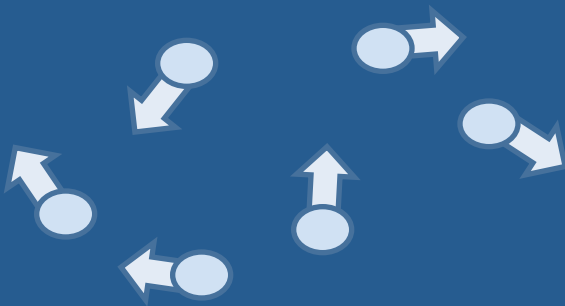

With no applied voltage the electrons in the conductor move in random directions. The net effect is no electrical current is produced.

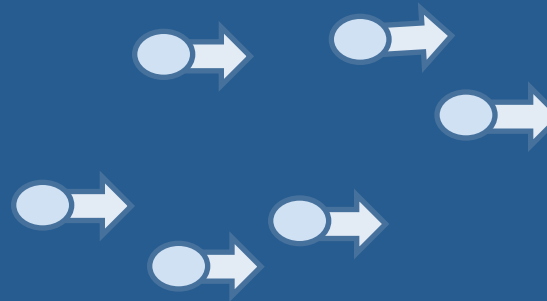

With an applied voltage the electrons in the conductor move along the potential gradient. The net effect is an electrical current is produced.

Insulators

In an insulator the crystal lattice contains very few free electrons. There are thus very few electrons available to constitute a current flow. Even a very large potential (thousands or millions of volts) cannot cause a significant current flow.

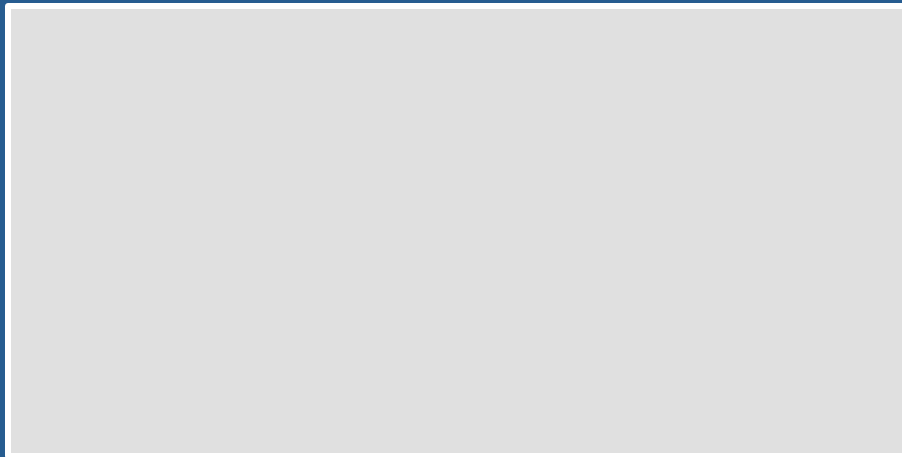

Conductor

Conductors and Insulators

Conductors

Copper
Aluminium
Gold
Silver
Brass
Carbon
Salt Water*

Insulators

Wood
Glass
Ceramic
Plastic
Pure Water*

** Water is not a good conductor in its pure state. Dissolved salts make it a better conductor. (Wet hands and sweat will be a sufficiently good conductor to allow a harmful current to flow and cause burns to the skin with a significant applied voltage.)*

Wet insulators may also conduct across their surface and may even “flash over” if the voltage is high enough.

Power, Potential Difference and Current

Power is the rate at which energy is transferred or dissipated. Only resistance can dissipate electrical power.

Potential Difference is the electrical pressure applied across a circuit or component causing the electrical gradient down which the electrons will move.

Current is the flow of electrons down the potential gradient. The more electrons in motion the greater the electrical current.

In dc circuits Power (P), Potential Difference (V) and Current (I) are related by:

Power = Potential Difference x Current

$$P = V \times I \text{ (Watts)}$$

Power Triangle

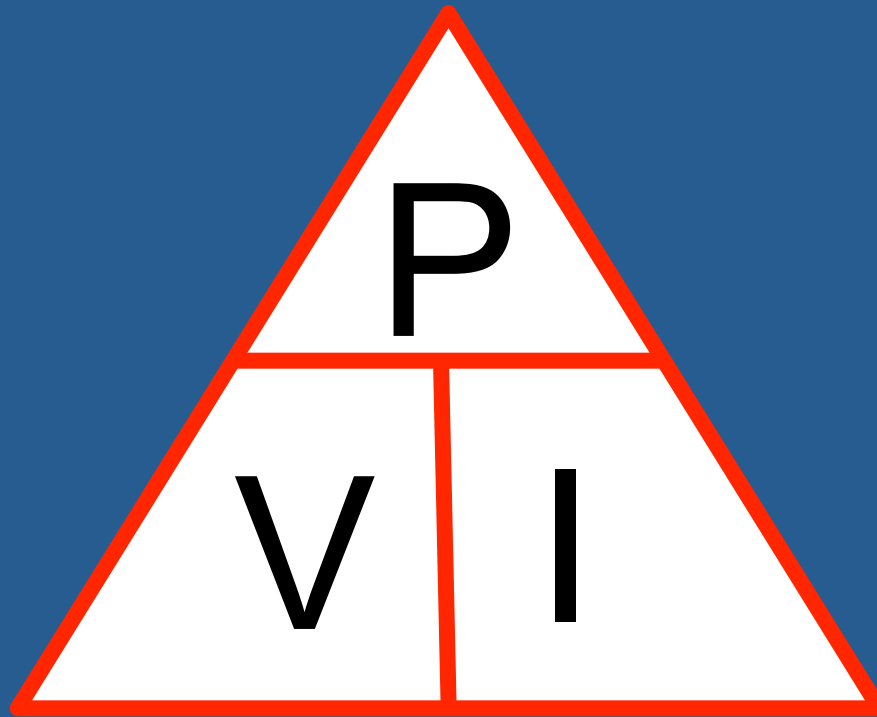

$$P = V \times I$$

$$V = (P / I)$$

$$I = (P / V)$$

eg. $V=5$ Volts, $I=3$ Amps, $P= 5 \times 3 = 15$ Watts

Power Examples

$$V = 9V, \quad I = 10\text{mA}, \quad P =$$

$$V = 10\text{kV}, \quad I = 1\text{mA}, \quad P =$$

$$P = 5\text{W}, \quad V = 5\text{V}, \quad I =$$

$$P = 2\text{kW}, \quad V = 230\text{V}, \quad I =$$

$$I = 1.5\text{A}, \quad P = 15\text{W}, \quad V =$$

$$I = 20\text{mA}, \quad P = 400\text{mW}, \quad V =$$

$$V = 9\text{V}, \quad I = 1\text{mA}, \quad P =$$

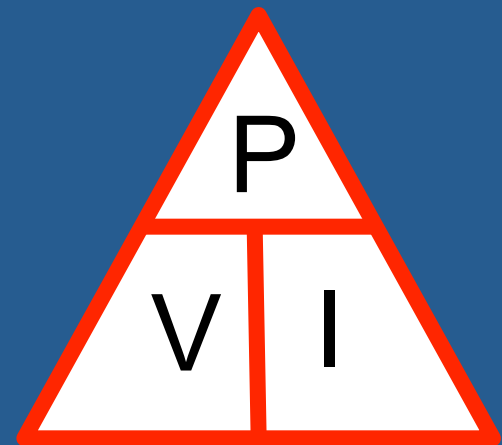

Potential Difference, Current and Resistance

Resistance is the property of a component, device or circuit which opposes the flow of current through it.

Resistance has the units of ohms (Ω).

Potential Difference and current are related to Resistance by the equation:

Potential Difference = Current x Resistance

$$V = I \times R \quad (\text{OHMS LAW})$$

eg. $I = 2$ Amps; $R = 10\Omega$; Given that $V = I \times R$ then $V = 2 \times 10$; $V = 20$ Volts.

Or, put another way, a potential difference of 20 Volts applied across a resistance of 10Ω will cause a current of 2 Ampères to flow through it.

Ohms Law Triangle

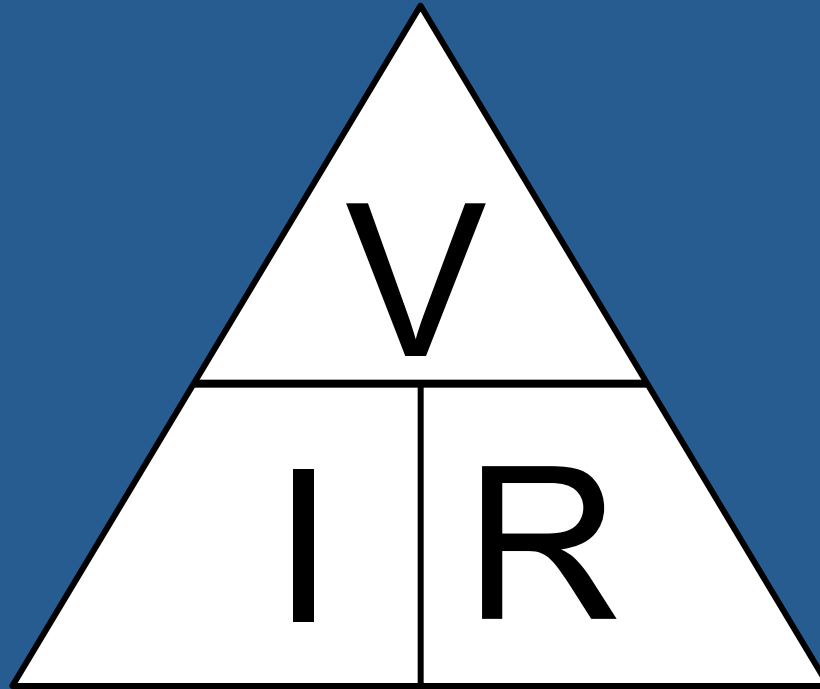

$$V = I \times R$$

$$I = V / R$$

$$R = V / I$$

eg. $V = 5V$, $I = 10 \text{ mA}$; Given that $R = V / I$ then $R = 5 / 0.01$, $R = 500\Omega$

(Watch the multiplier prefixes. Always convert to the raw number if you are not sure!)

Ohms Law Examples ($V = I \times R$)

Complete the table below using Ohms Law. (WATCH THE UNITS!!!)

Voltage V	Current	Resistance Ω
	1 Amp	30
	1mA	3000
	2mA	10,000
50	10mA	
18	3	
10		1000
1mV		0.1

Resistors

Resistors are two terminal, passive devices. It does not matter which way round you connect them in a circuit. The symbol for a resistor is:



The value of a resistor (leaded components) is indicated by coloured bands around the device. (See handout).

In circuit diagrams the value is written close to the symbol. For example:



$$3k3 = 3,300\Omega = 3.3k = 3.3k\Omega$$

3k3 is the preferred method of writing the value

Series Connexion of Resistors

Series connexion of resistors is where two or more are daisy-chained, head to tail with each other.



You can connect two or more resistors in this way. The final result is still a two-terminal device which has an equivalent resistance (R_e) equal to the sum of the individual resistance values. So, for two resistors in series the equivalent resistance is:

$$R_e = (R_1 + R_2);$$

Three resistors in series has an $R_e = (R_1 + R_2 + R_3);$

For n resistors in series the general expression is: $R_e = \sum_{n=1}^n R_n$

Series Connexion: Example



$$R_e = 3k3 + 4k7 = 3300 + 4700 = 8k0 \text{ or } 8000\Omega$$



$$R_e = 2k2 + 560 = 2200 + 560 = 2k76 \text{ or } 2760\Omega$$



$$R_e = 10k + 1k0 + 680 = 11k68 \text{ or } 11,680\Omega$$

NB! Beware of mixed prefixes! (M, k, R)

(10M + 33k) is: 10,033K or 10.033M or 10,033,000Ω

Resistors in Parallel

As well as series connexion you can connect resistors in parallel. This also gives a two terminal device with an equivalent resistance R_e . (However this R_e is a different value to the R_e formed by two resistors in series.)

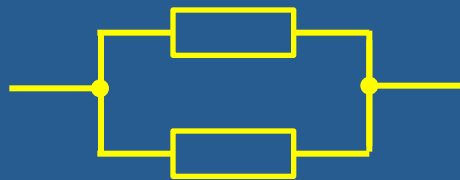

$$\frac{1}{R_e} = \frac{1}{R_1} + \frac{1}{R_2}$$

In general the equivalent resistor for several resistors in parallel is: $\frac{1}{R_e} = \sum_{n=1}^n \frac{1}{R_n}$

eg. $R_1 = 5\Omega$ and $R_2 = 10\Omega$;

$$\frac{1}{R_e} = \frac{1}{R_1} + \frac{1}{R_2};$$

$$\frac{1}{R_e} = \frac{1}{5} + \frac{1}{10}$$

$$\frac{1}{R_e} = \frac{2}{10} + \frac{1}{10}$$

$$\frac{1}{R_e} = \frac{3}{10}$$

$$R_e = \frac{10}{3}$$

$$R_e = 3.33\Omega$$

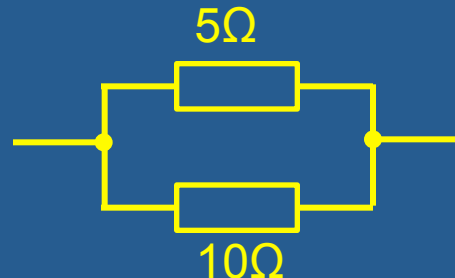

Resistors in Parallel: Worked Example

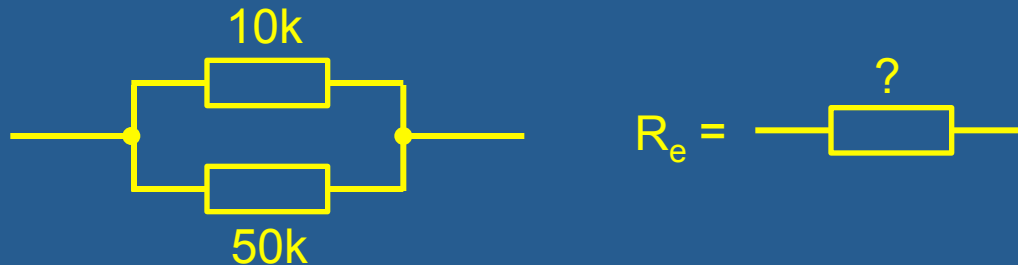

$$1/R_e = (1 / 10,000 + 1 / 50,000)$$

$$1/R_e = (5 / 50,000 + 1 / 50,000)$$

$$1/R_e = (6 / 50,000)$$

$$R_e = (50,000 / 6)$$

$$R_e = 8k33$$

Check: The value for R_e must always be less than the smallest value of resistance in the parallel combination.

Resistors In Parallel: Try These

(a): 10k, 33k

(b): 27k, 47k

(c): 27k, 39k, 56k

(d): 10k, 10k

(e): 10k, 10k, 10k

What is special about the R_e resulting from identical resistor values in parallel?

Identical Resistors In Parallel

Two 10Ω resistors in parallel.

$$1 / R_e = 1 / 10 + 1 / 10$$

$$1 / R_e = 2 / 10$$

$$R_e = 10 / 2$$

$$R_e = 5\Omega$$

Three 10Ω resistors in parallel

$$1 / R_e = 1 / 10 + 1 / 10 + 1 / 10$$

$$1 / R_e = 3 / 10$$

$$R_e = 10 / 3$$

$$R_e = 3.33\Omega$$

If, and only if, identical resistors are connected in parallel then the final value is equal to an element value divided by the number of resistors in the parallel combination. The final value is always less than an element value.

Four 12Ω in parallel give $12/4 = 3\Omega$

Three 12Ω in parallel give $12/3 = 4\Omega$

Two 12Ω in parallel gives $12/2 = 6\Omega$

Alternative Equation For Parallel Resistors

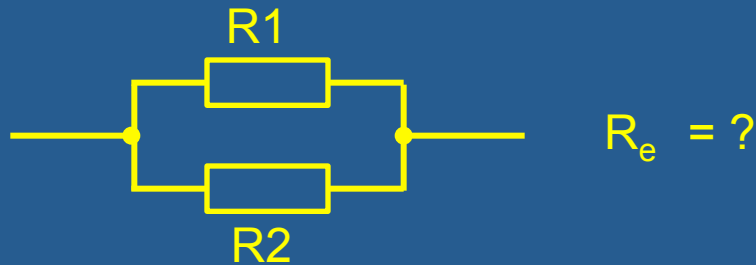

$$R_e = \left[\frac{R1 \times R2}{R1 + R2} \right]$$

For example: $R1 = 10R$ and $R2 = 5R$

$$R_e = [(10 \times 5) / (10 + 5)]$$

$$R_e = (50 / 15)$$

$$R_e = 3R33$$

For more than two resistors in parallel work out the value for the first pair. Then use this value in parallel with R3, then the value of this combination in parallel with R4 and so on.

Resistive Networks and Ohms Law

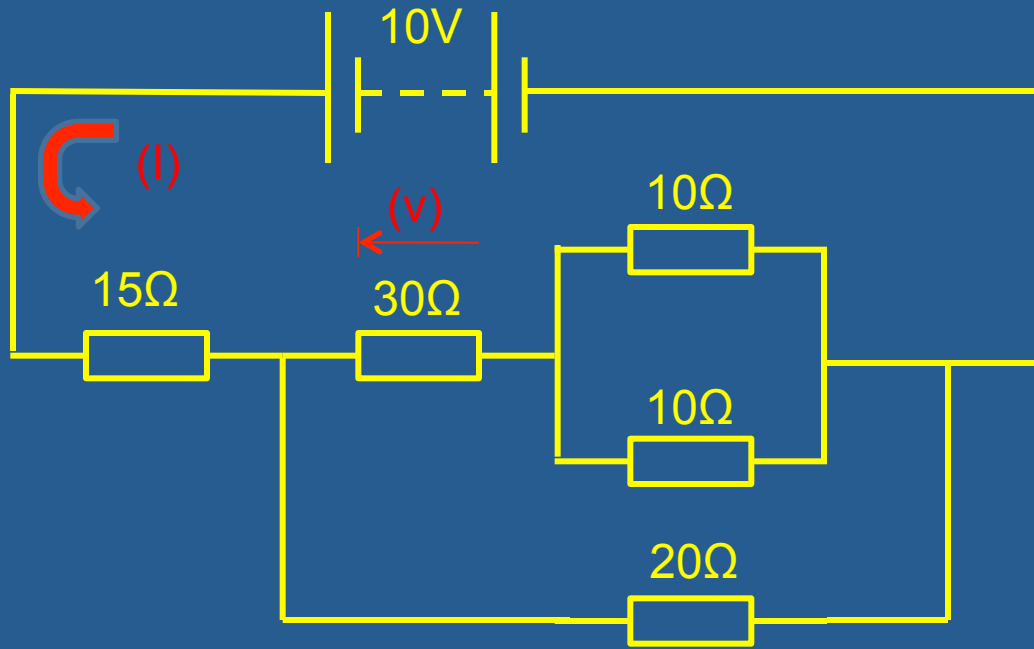

1. Calculate the total current (I) delivered by the battery.

2. What is the voltage (V) across the 30Ω resistor?. *(This is not as difficult as it may first look!)*

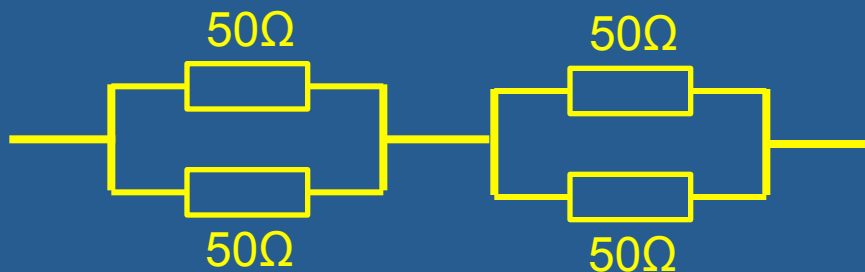

What is the equivalent value in ohms (R_e) of this combination?

Cells in Parallel and Series

***BE CAREFUL!** When connecting cells in parallel or series and when dealing with cells that can deliver significant currents (eg NiCads and Lead Acid types),*

DO NOT:

- Mix cell types;*
- Parallel connect cells of different emfs;*
- Reverse the polarity of any cell in the battery.*

Cells in Series



A single lead-acid cell has an emf of 2.2 Volts when fully charged.

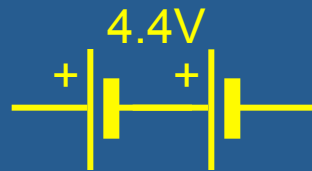

Two, lead-acid cells when connected in series have a combined emf of 4.4 Volts across them.

Two or more cells connected in series form a battery.

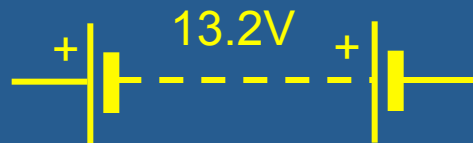

Six, lead acid cells in series form a battery (sometimes called an accumulator) of 13.2 Volts. This is a standard car battery voltage. *(Strangely, this is always wrongly described as a 12 Volt battery!)*

Cells in Series

Cells in series connect positive to negative (head to tail).

The final battery voltage is the sum of the individual emfs of the constituent cells.

The total circuit current flows through each cell in the series battery when the battery is connected to an external circuit.

Cells in Parallel

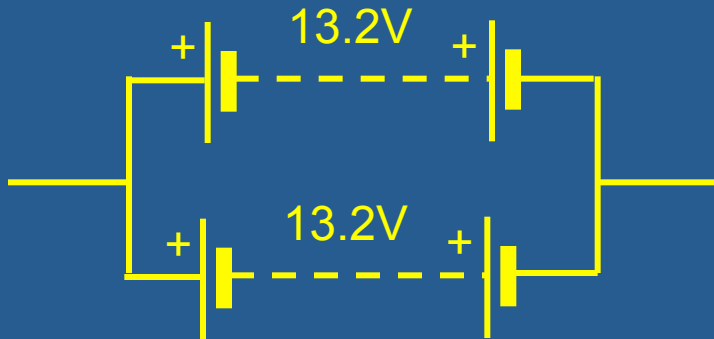

Connecting batteries in parallel is done to increase the stored energy.

If you really must connect two or more high capacity batteries in parallel BE VERY CAREFUL.

DO YOU REALLY NEED TO DO IT?

Two 13.2 Volt batteries connected in parallel will produce a battery with a terminal emf of 13.2 Volts.

However the total current which the combination of the two batteries can provide is twice the current that one of the pair can provide. (Similarly total charge).

Each of the batteries above will provide half of the total current when an external circuit is connected. (This assumes that both component batteries are absolutely identical.)

Primary and Secondary Cells.

Cells store charge in the form of chemical energy.

Primary cells, once depleted, cannot be recharged.

Secondary cells, once depleted, can be recharged.

Connecting the depleted battery to a suitable charger will reverse the chemical process by supplying charge back into the battery.

The process is not 100% efficient. You have to put back more charge than you took out to restore the battery to fully charged. This additional charge is to compensate for losses within the cells.

Battery Ratings

Lead Acid batteries are normally rated at “*The 10 hour rate*”. This is their capacity when going from full charge to a fully discharged state at a constant rate of current delivery for a period of 10 hours.

(Note: Fully discharged is not when the terminal voltage is 0 Volts!)

The recharging rate should not normally exceed the 10 hour rate as well.

For example:

A 20Ahr (Ampere Hour) battery has a 10 hour rating of being able to deliver a current of 2 Amps for 10 hours. You would recharge it at 2 Amps.

A 50Ahr battery could deliver 5 Amps for 10 hours.

In theory a 50Ahr battery would also deliver 50 Amps for 1 hour as well. (Or any other combination giving a product of 50Ahr) However, in practice, losses and chemistry do not allow this.

The Capacitor

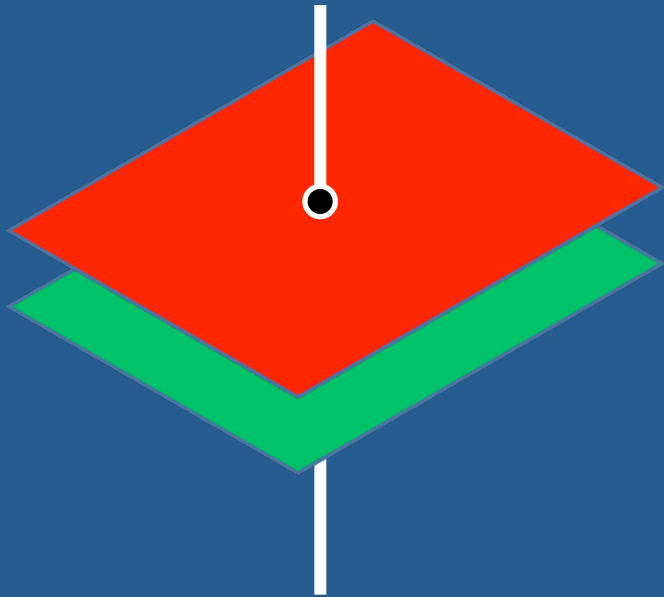

The value that a parallel plate capacitor has is dependent upon three factors:

1. The area (A) of the plates;
2. The distance (d) between the plates;
3. The dielectric between the plates.

The bigger the area of the plates and the closer together that they are the correspondingly bigger is the value of the capacitor that is formed.

Inserting a dielectric (plastic, mica, etc) between the plates also increases the value of the capacitance above that when the plates are separated by air or a vacuum.

Capacitance Value

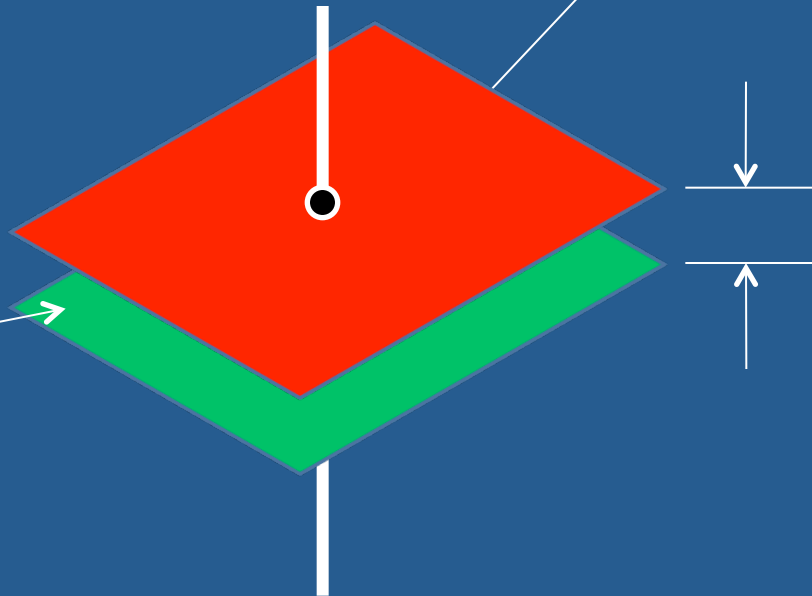

Area of plate = A square metres

Separation between the plates is d metres

The gap between the plates is filled with air or a dielectric material

The value of such a capacitor is:

$$C = \frac{A\epsilon_0\epsilon_r}{d}$$

Where C is in Farads

The Dielectric

$$C = \frac{A\epsilon_0\epsilon_r}{d}$$

These two terms apply to the *dielectric* which lies between the two plates. (The A and d terms are somewhat easier to understand.)

ϵ_0 This is the *vacuum permittivity* of free space. It is a measure of how much resistance is encountered in forming an electric field.

Vacuum Permittivity $\epsilon_0 = 8.85 \times 10^{-12}$ Farads/metre

ϵ_r This is the *relative permittivity* of a substance. This is also called the dielectric constant. So, paper which has a dielectric constant of about 2.3 relative to that of a vacuum would increase the value of a plate capacitor by a factor of 2.3 if it were inserted between the plates instead of leaving air to fill the gap. (It's actual permittivity is simply $2.3\epsilon_0$)

ϵ_r In Practice

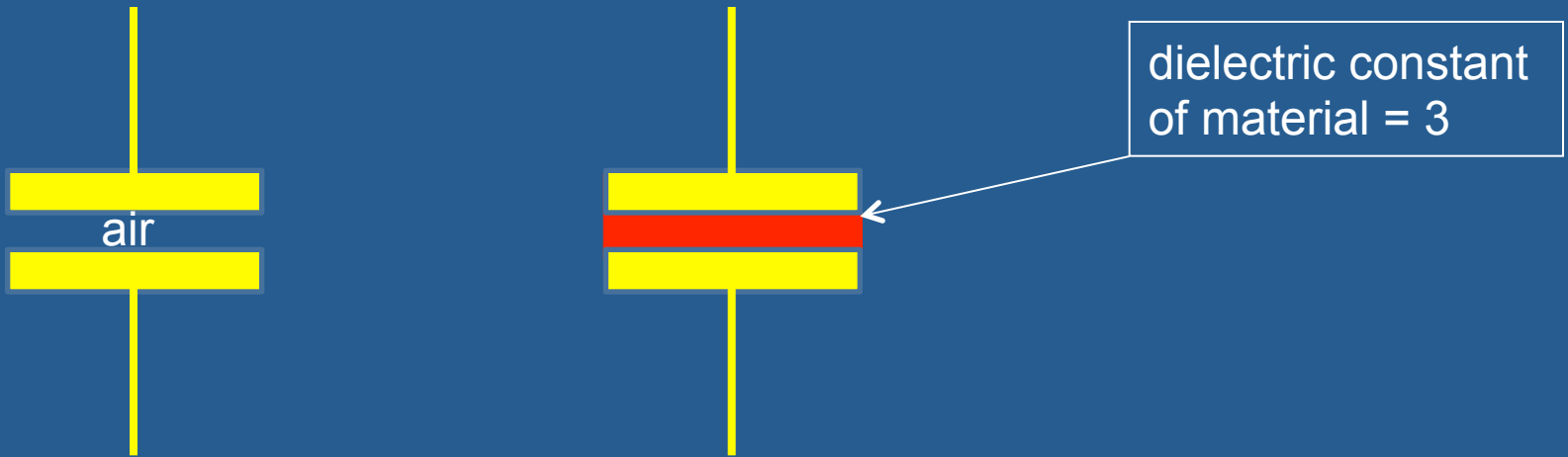

Area of plates = 1 square metre, separation distance = 0.01 metre.

Value of air-spaced capacitor = $\{(1 \times 8.85\text{E-}12 \times 1) / 0.01\}$ = 885 pF

Value of dielectric-spaced capacitor = $\{1 \times 8.85\text{E-}12 \times 3) / 0.01\}$ = 2655 pF

The dc Response Of A Capacitor

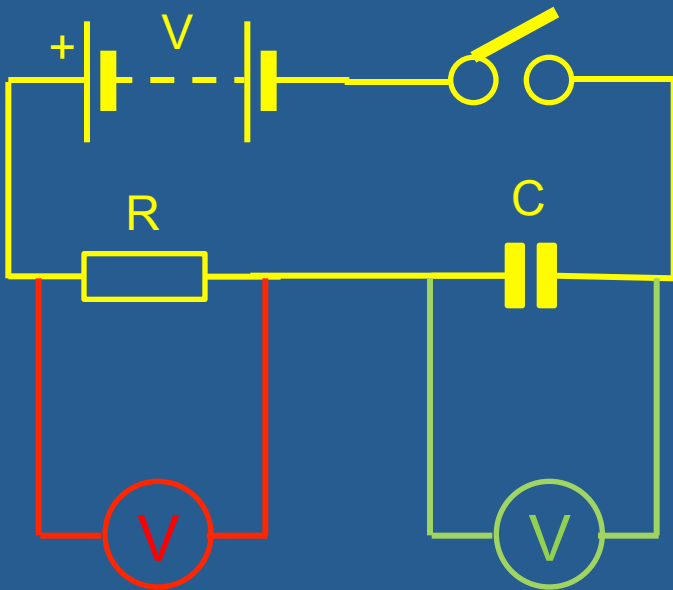

The switch is closed at $t=0$. Initially the capacitor appears to have 0Ω resistance and the current is limited by the value of R . The voltage then rises exponentially across C to reach V and falls exponentially across R to reach $0V$

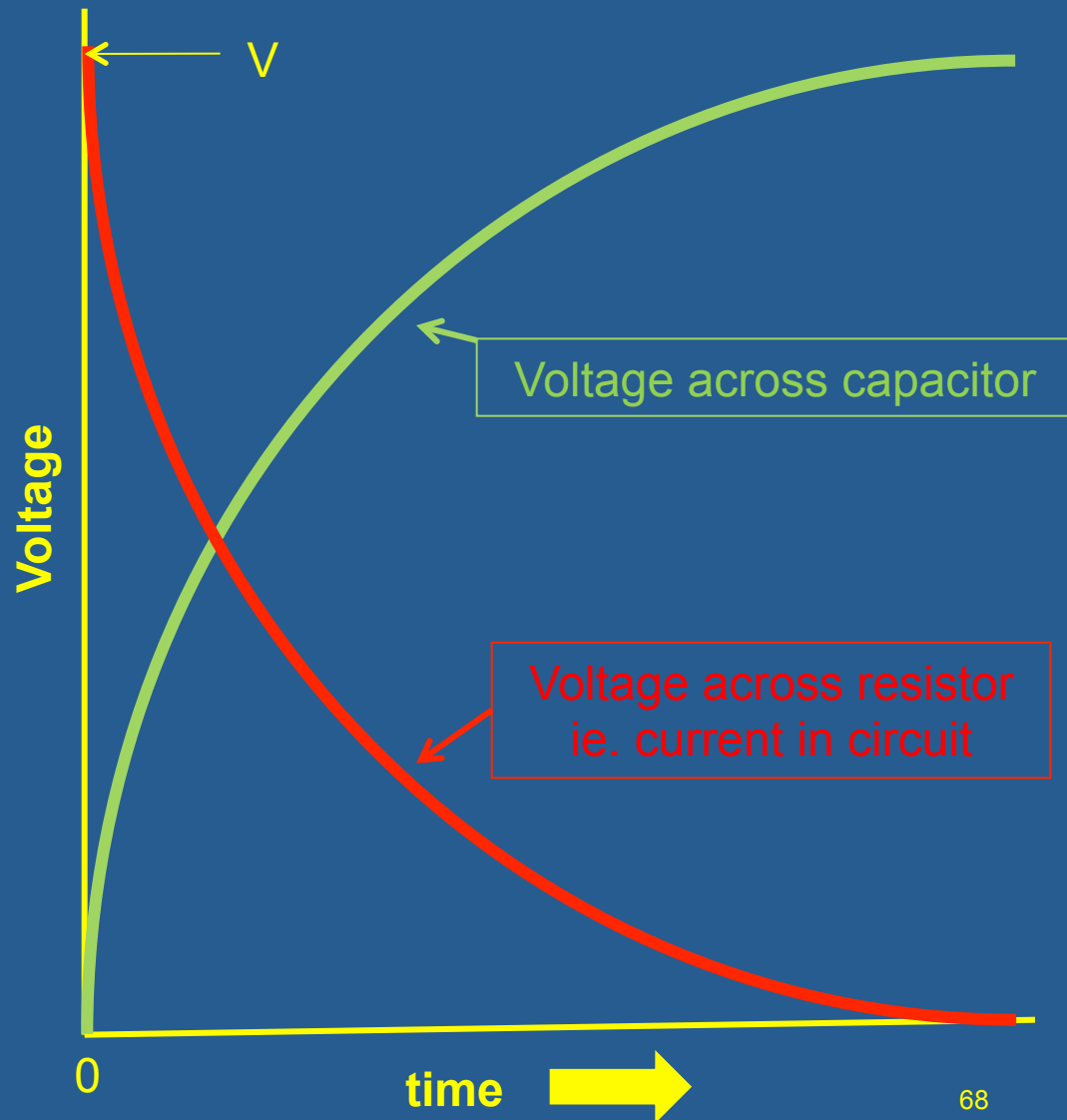

Charging and DC Blocking

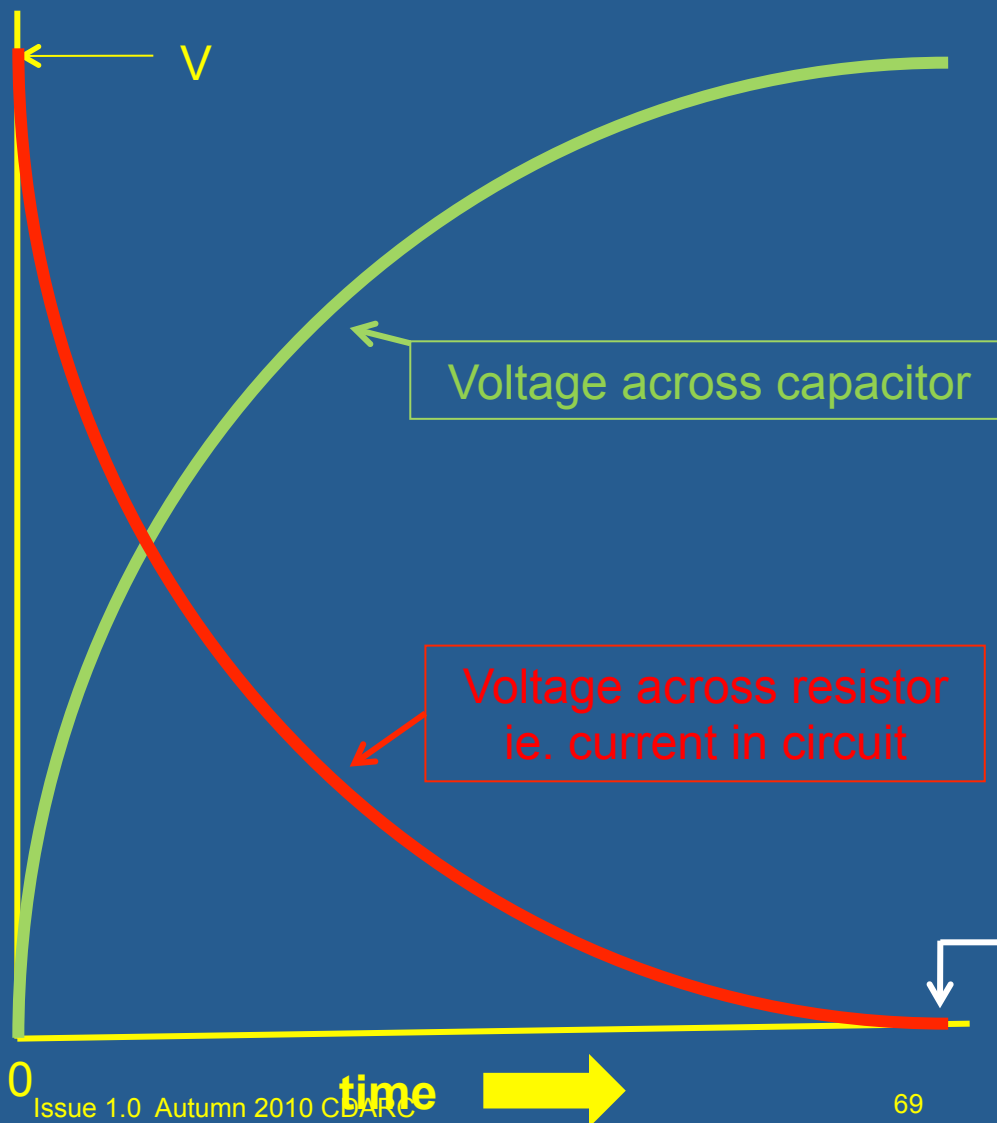

When the switch is closed current flows from the battery through R and C. C begins to charge. As the charge on C builds the current drops exponentially. Eventually C becomes fully-charged and no further current flows.

A fully-charged capacitor will “block” the flow of dc in a circuit.

The time it takes for C to become fully-charged depends upon the value of C and R

Flow of dc blocked from this point onwards

The ac Response Of A Capacitor

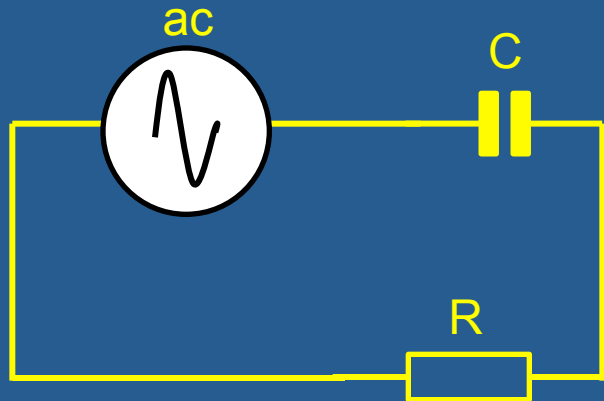

When supplied with an alternating current (ac) the capacitor will alternately charge and discharge in sympathy with the supply. As the supply reverses in polarity the capacitor can charge and discharge.

The net effect of this movement of charge is, of course, a current which flows in the circuit. Thus, under ac conditions, a capacitor will pass a current.

Thus a capacitor will not block ac signals. This allows a capacitor to pass signals (couple) one part of a circuit to another without upsetting any dc bias voltages – which it will block.

Polarised Capacitors



Large value capacitors are polarised devices. This means that they have a positive and negative terminal. (They will not work if their polarity is reversed.) The positive terminal must always be kept at a more positive potential with respect to the negative.

These capacitors will destroy themselves spectacularly and noisily if they are connected with reverse polarity!

They also have a rated voltage which must not be exceeded.

Inductors

An inductor is usually a coil with one or more turns of wire wound around a circular former. (Sometimes, with stiff wire the former is removed and the coil shape is self-supporting.)

The characteristics of a coil come from:



n : the number of turns;
 L : the winding length;
 D : the coil diameter

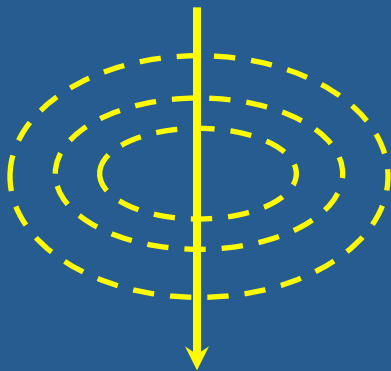

A current flowing down a wire will produce a uniform, circular, magnetic field around the wire.

Energy Stored In A Magnetic Field

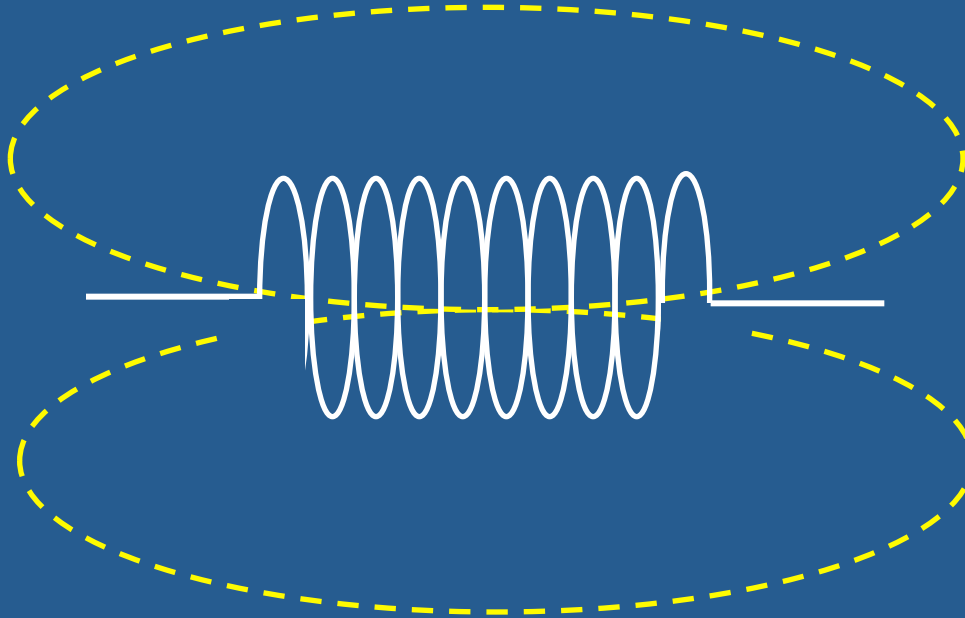

A coil (solenoid) concentrates the magnetic field lines along the axis of the coil. These field lines store energy magnetically. This ability to store energy is a property of inductance.

The value of the inductance depends upon the number of turns, coil diameter, length of winding and any material inside the coil (ferrite etc)

Tuned Circuits

A combination of an inductor and a capacitor in either a series or parallel combination will form a tuned or resonant circuit.



Series resonant or acceptor circuit

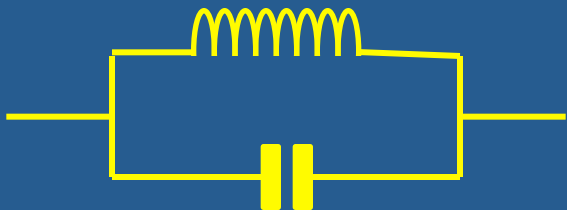

Parallel resonant or rejector circuit

The values of the inductor and the capacitor determine the actual resonant frequency.

At resonance a series resonant tuned circuit has a low impedance (ac resistance). The parallel tuned circuit at resonance has a high impedance

Resonant Frequency

The energy stored in the capacitor (C) and in the inductor (L) transfers backwards and forwards between them at resonance.

This happens at a fixed or resonant frequency.

The actual value of C and the actual value of L determine this resonant frequency.

If the value of L and C are the same in the series and the parallel tuned circuit then the resonant frequency will be the same for both circuits. Varying L or C will vary the resonant frequency accordingly.

Uses Of Tuned Circuits

In radio work there are many uses for the tuned circuit and the property of resonance.

(a): Suppose that we have a 2kHz whistle on an audio signal. If we can construct a resonant circuit that behaves like a short-circuit only at 2kHz then we could shunt the whistle to ground (ie eliminate it) whilst allowing all the wanted frequencies to pass.

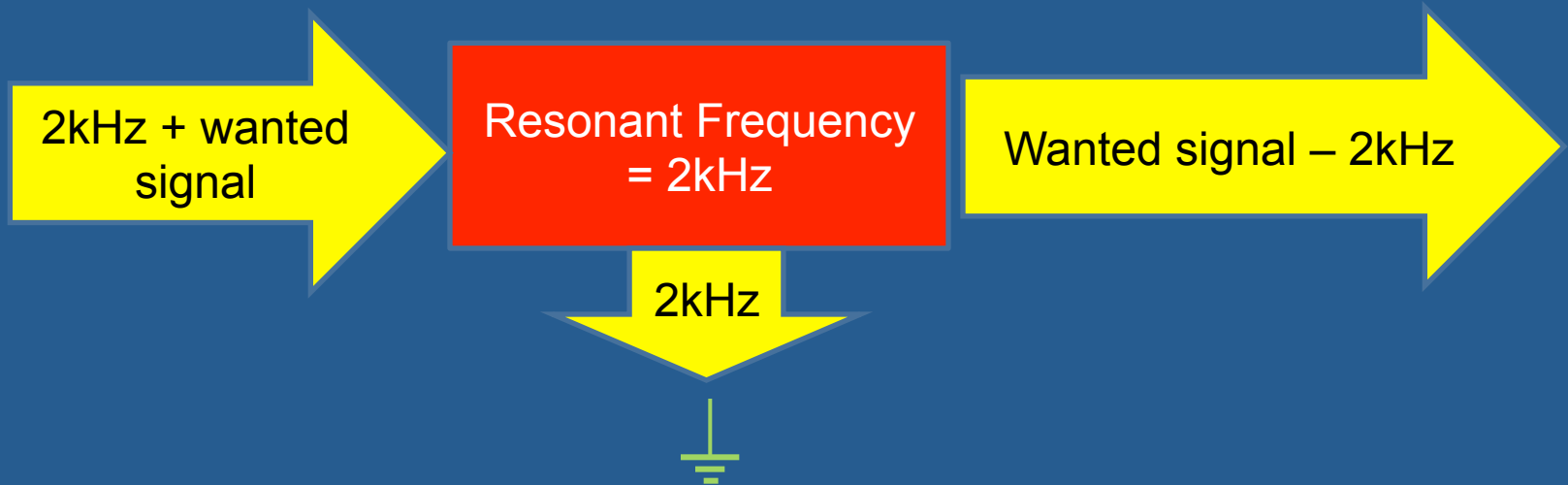

Use Of Tuned Circuits

(b): We can similarly construct a rejector circuit which will reject every frequency except the wanted one.

Suppose we want to reject all frequencies except 10.7MHz. We would make a circuit that looks like a short circuit to earth at every frequency except 10.7MHz.

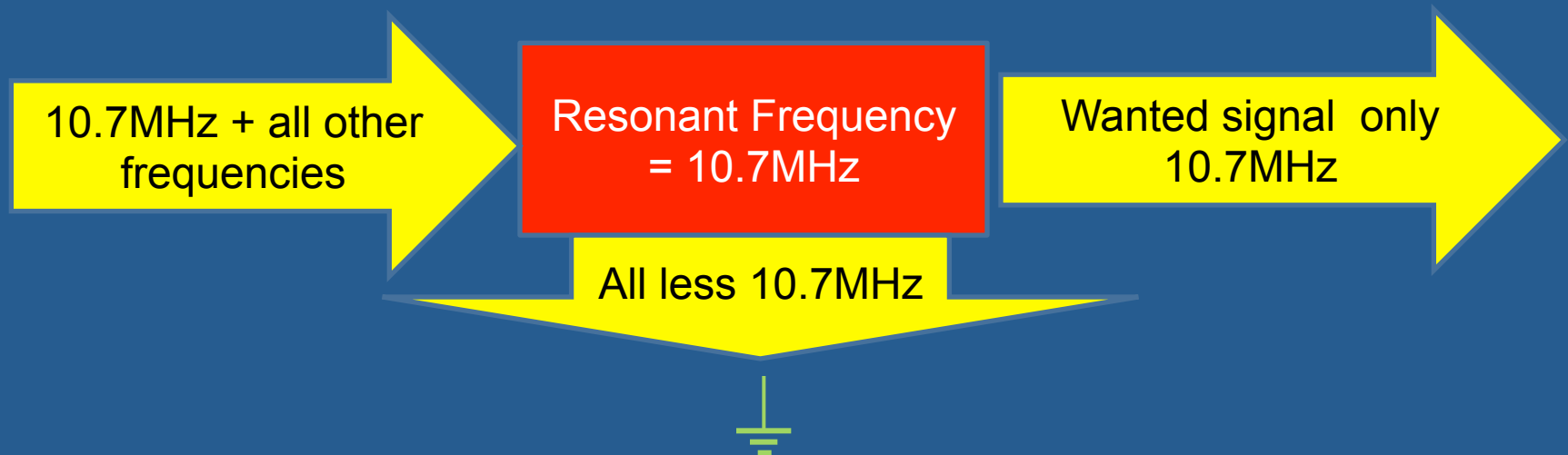

Transformers

A simple transformer comprises two, separate coils of wire that share a common, soft iron core

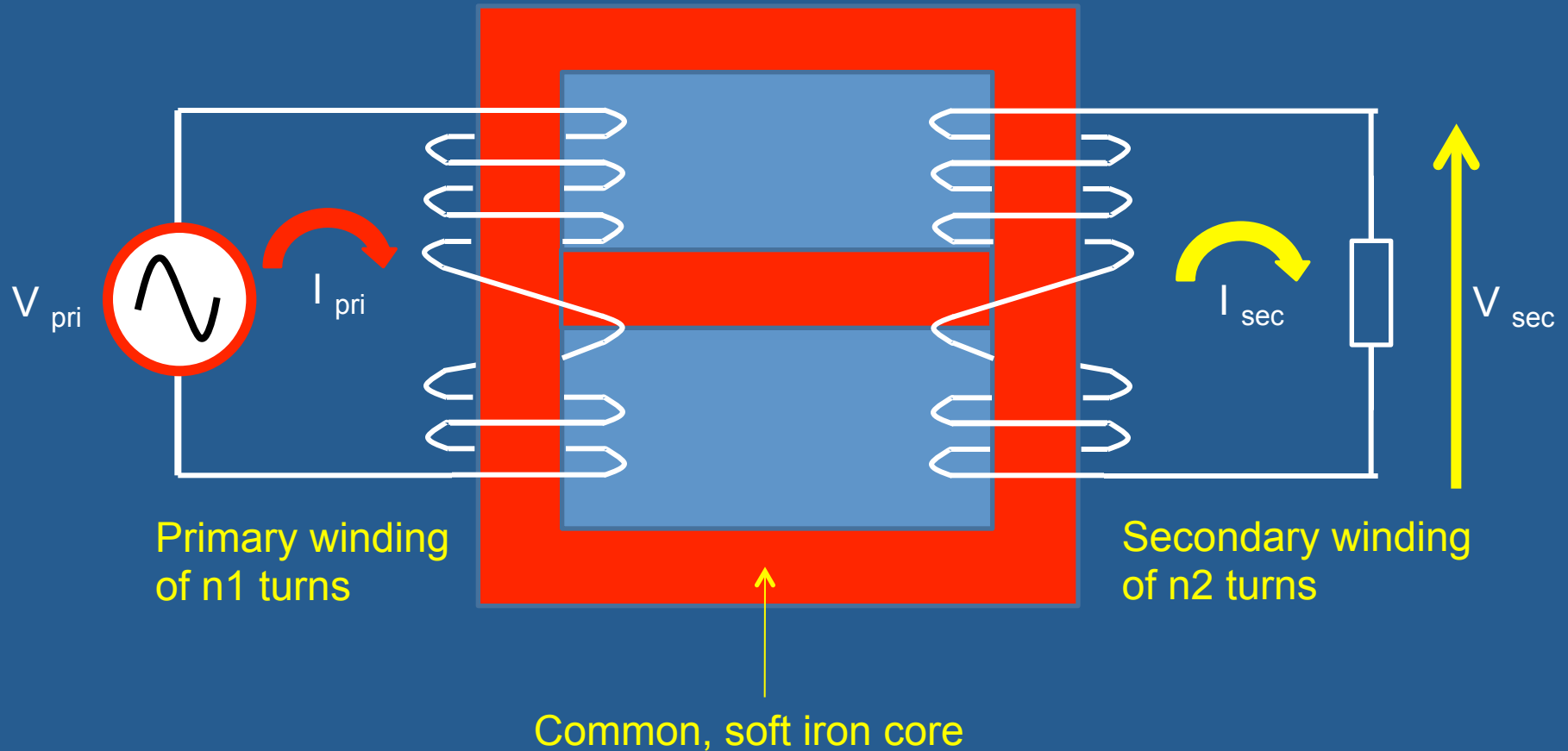

Transformer Operation

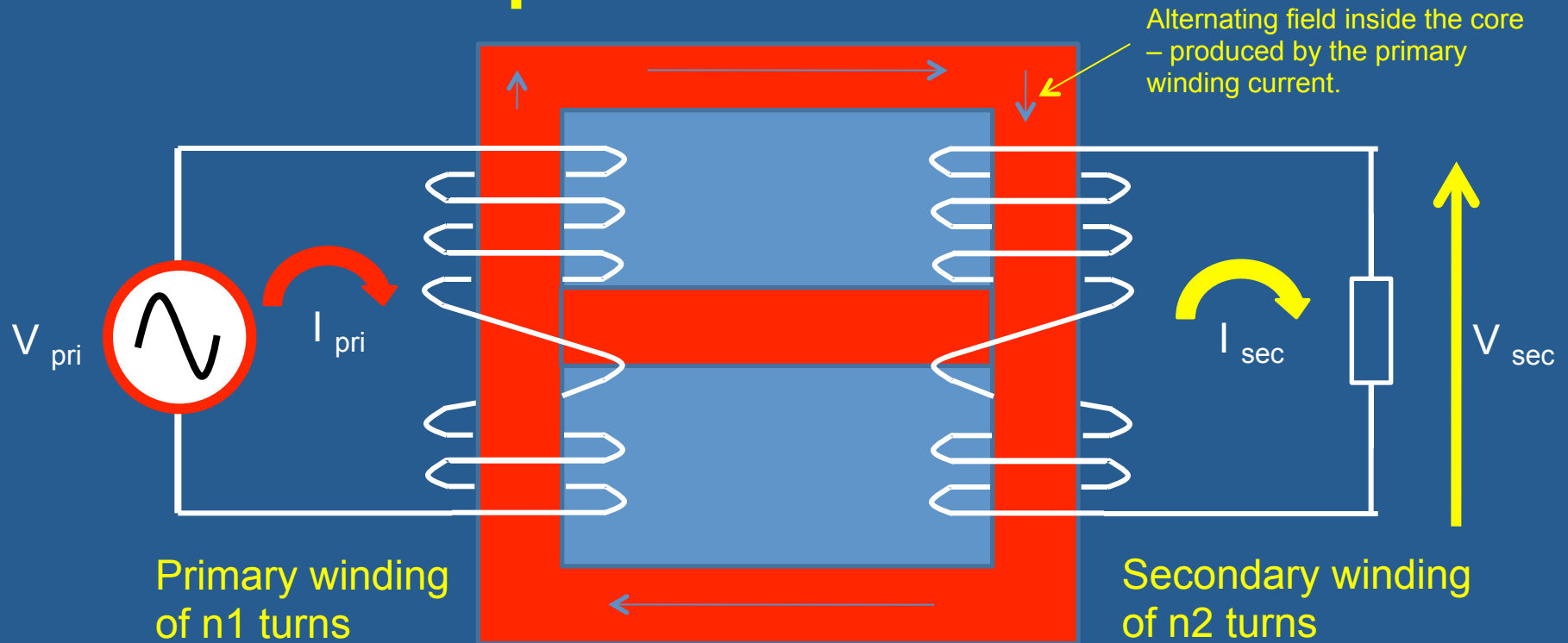

When the primary winding is energised with an ac supply the current flowing in the primary windings creates a magnetic field in the core which alternates at the same frequency as the supply. This current is constrained within the iron core of the transformer. This fluctuating field induces a voltage in the secondary windings of the transformer. There is no direct connexion between the primary and secondary windings. They are linked magnetically. It is an ac device. You cannot have a dc transformer.

Transformer – Key Relationships

$$\left[\frac{V_{\text{pri}}}{V_{\text{sec}}} \right] = \left[\frac{n_{\text{pri}}}{n_{\text{sec}}} \right] = \left[\frac{I_{\text{sec}}}{I_{\text{pri}}} \right]$$

Voltage
ratio

Turns
ratio

Current
ratio

Step-Up Transformer

By having a turns ratio($n_1 : n_2$) between the primary and secondary which is something other than unity you can make the induced secondary voltage differ from the primary voltage.

For example: A transformer has a primary voltage of 230 Volts. There are 200 turns on the primary winding and 1000 turns on the secondary winding. What will the secondary voltage be?

$$\left[\frac{n_{\text{pri}}}{n_{\text{sec}}} \right] = \left[\frac{V_{\text{pri}}}{V_{\text{sec}}} \right] = (200 / 1000) = (230 / V_{\text{sec}})$$

$$V_{\text{sec}} = (230 \times 1000) / 200$$

$$V_{\text{sec}} = 1,150 \text{ Volts}$$

ie $V_{\text{sec}} = V_{\text{pri}} \times \text{winding ratio}$

Step-Down Transformer

A transformer has 200 turns on the primary and 40 turns on the secondary winding. The primary voltage is 230 Volts. What is the secondary voltage?

$$\left[\frac{n_{\text{pri}}}{n_{\text{sec}}} \right] = \left[\frac{V_{\text{pri}}}{V_{\text{sec}}} \right]$$

$$200 / 40 = 230 / V_{\text{sec}}$$

$$V_{\text{sec}} = (40 \times 230) / 200$$

$$V_{\text{sec}} = 46 \text{ Volts}$$

$$\text{ie } V_{\text{sec}} = V_{\text{pri}} / \text{winding ratio}$$

Power Transfer

In an ideal transformer the *power delivered* to the primary will be identical to the *power extracted* from the secondary.

However, there are inevitable losses. In practice, however, you can generally ignore these.

So:

$$(V_{\text{pri}} \times I_{\text{pri}}) = (V_{\text{sec}} \times I_{\text{sec}})$$

If the secondary voltage is stepped down (up) by a factor of 5 then the secondary current is stepped up (down) by the same factor to maintain constant power across the transformer.

Transformer Power Transfer

Turns ratio 10:1 step down

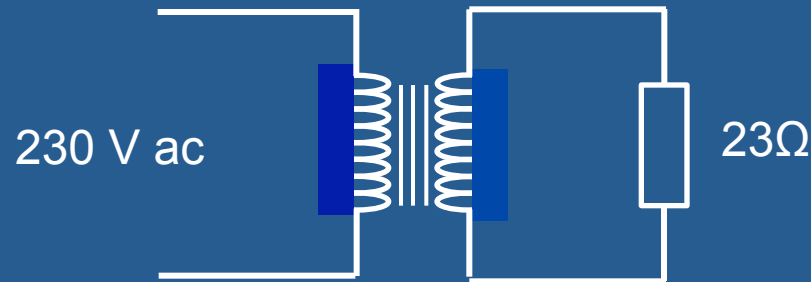

The transformer secondary voltage will be $(230 / 10)$ volts. ie 23 Volts.

The secondary current will be $(23 \text{ Volts} / 23\Omega)$ amps. ie 1 Ampère.

The secondary power will be $(23 \text{ Volts} \times 1\text{A})$ Watts. ie 23 Watts

The primary power is also 23 Watts (neglecting losses)

The primary current will be $(230 \text{ Volts} / 23 \text{ Watts})$ amps. ie 0.1 Ampères

The secondary current is x10 the primary current at 1/10th of the primary voltage

The Semiconductor Diode

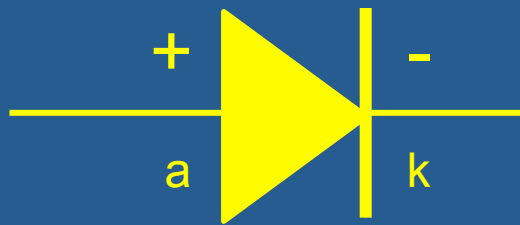

a: anode; k: cathode

When conducting (ie forward biased) a silicon, semiconductor diode has a forward voltage drop of about 600mV across it. It will maintain this voltage drop across its specified current range. (More or less!). This means that it will not start to conduct until at least 600mV is applied across it and the anode is positive with respect to the cathode by this amount.

When the diode is reverse biased (ie anode negative with respect to the cathode) it will not conduct and exhibits a very high resistance to current flow.

Cat Flap Analogy

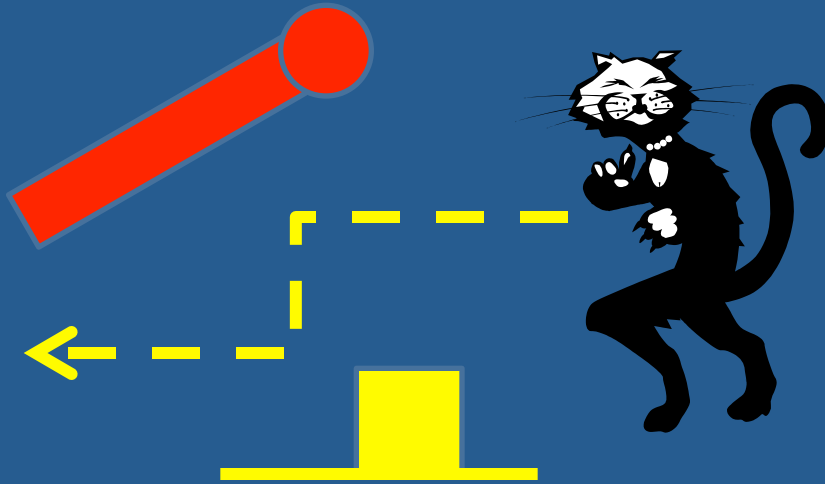

Forward biased

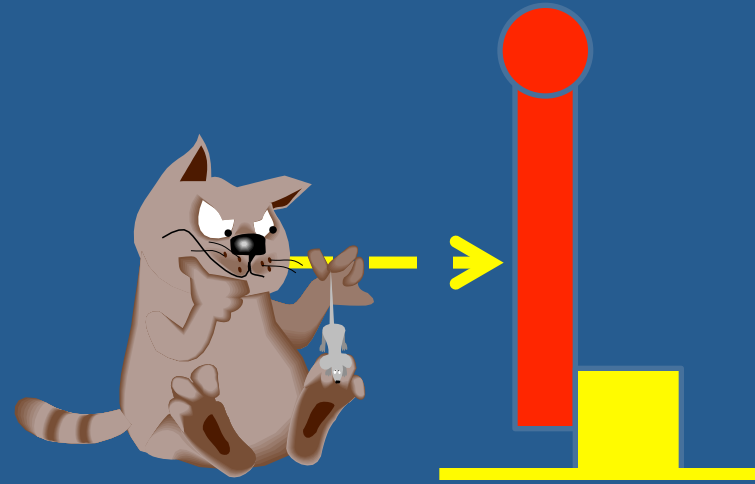

Reverse biased

Simple Rectification Of AC: (The Half-Wave Rectifier)

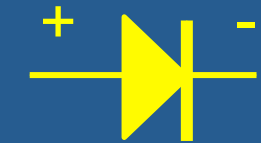

Forward Bias



Reverse Bias



Forward biased

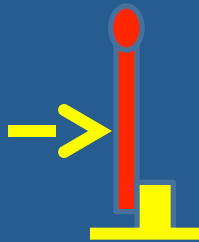

Reverse biased

A reminder about forward and reverse biasing. The diode will only conduct in one direction. That is when its anode is about 600mV positive with respect to its cathode.

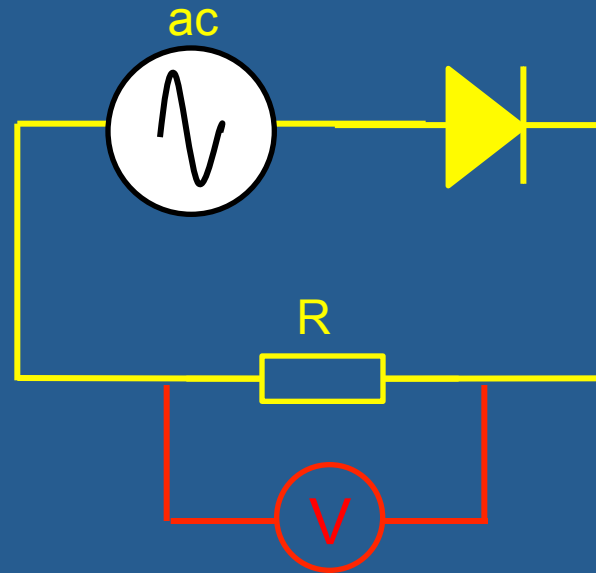

The above, simple circuit shows an ac generator connected to a diode and a series resistance. The ac voltage swings about the 0 Volts going alternately positive and negative. This will forward and reverse bias the diode in sympathy with the ac voltage. The voltage is read by a voltmeter.

Half-Wave Rectification

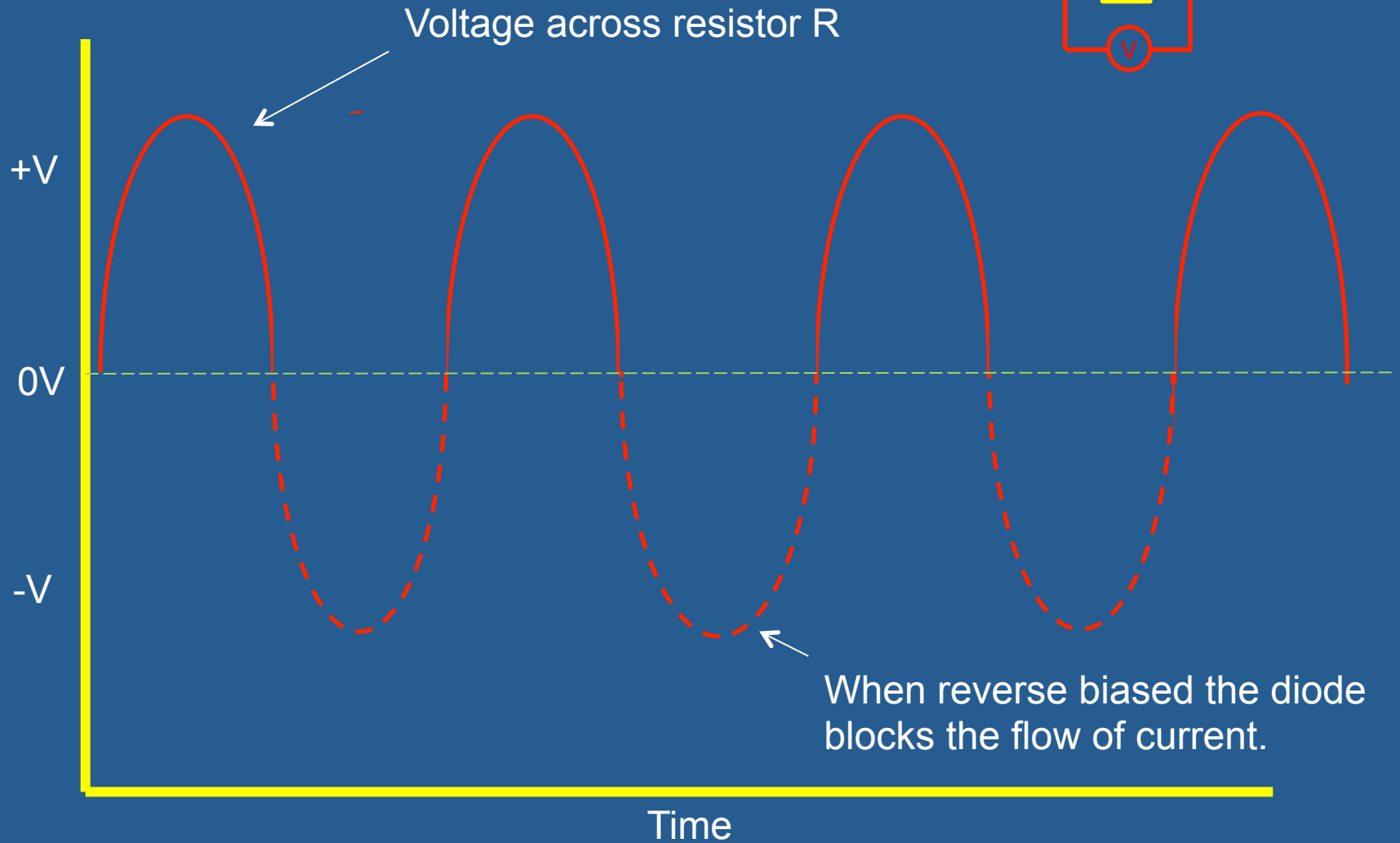
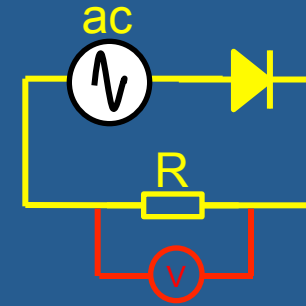

Transformer + Diode Rectification

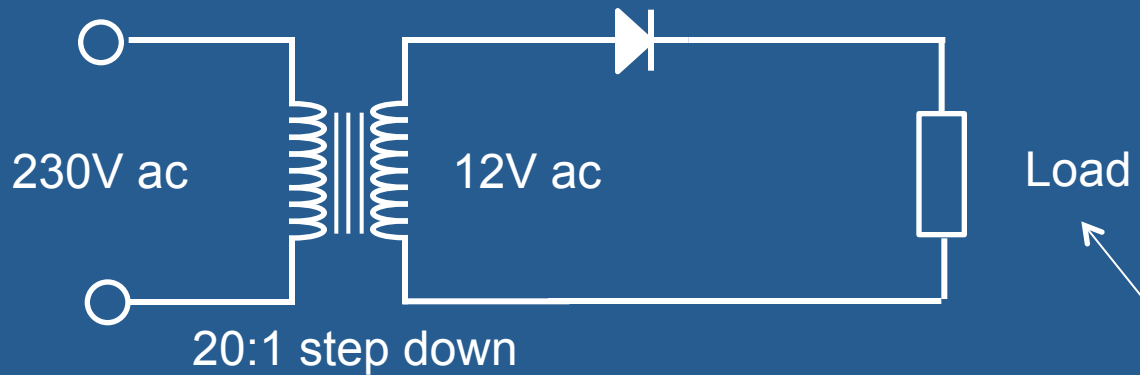

A single rectifier diode will produce pulsed dc in the load. This is fine for non-critical loads such as battery charging.

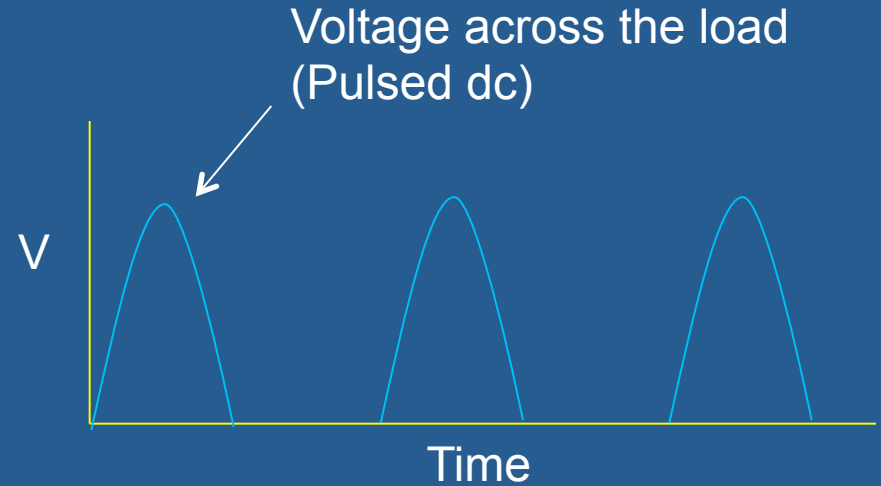
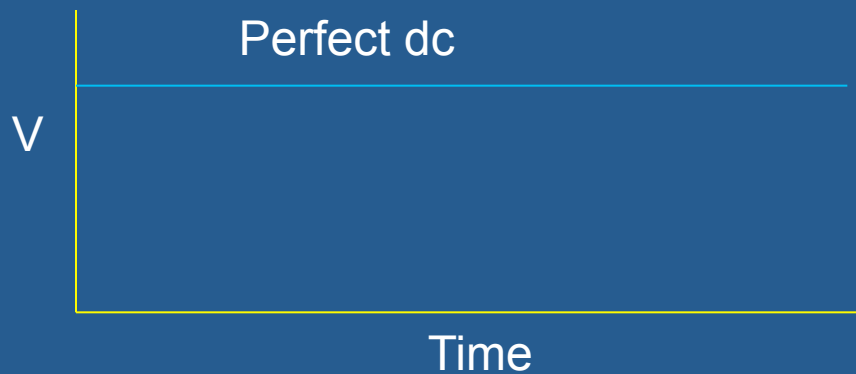

So how do you achieve a perfect dc output?

Smoothed dc Output

What we need is an electrical “flywheel”. This would store energy during a pulse and release it to the circuit when the diode was not conducting.

If it helps to visualise this then think of stored electrical charge like water in a cistern and the pulses like a tap filling that cistern - but turning on and off in a regular, pulsed way. You could arrange a supply of water out from the cistern that would be a continuous, steady flow. The store of water in the cistern would smooth out the pulsed flow from the tap,

The device for doing this electrically is known as a *reservoir capacitor*. This will store and release charge to give a smoother output which isn't heavily pulsed. (This is exactly similar to a water reservoir which stores and releases water over time to maintain a steady supply.)

Reservoir Capacitor – No Load Condition

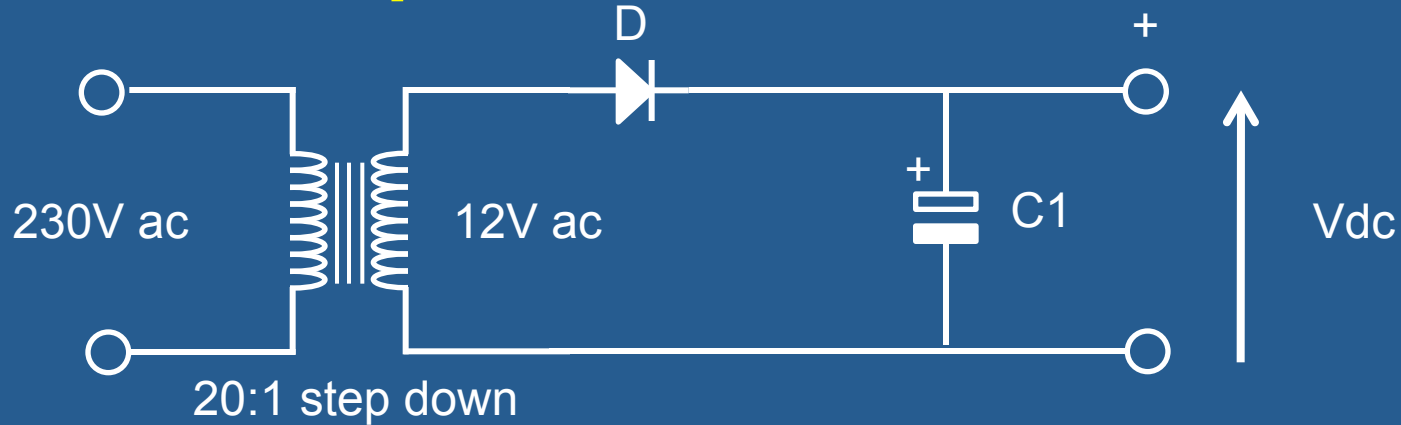

C1 is a large value, reservoir capacitor. (Typically this would be an electrolytic capacitor of several thousand microfarads.) When there is no load across the output the dc waveform will resemble the diagram below when the circuit is energised.

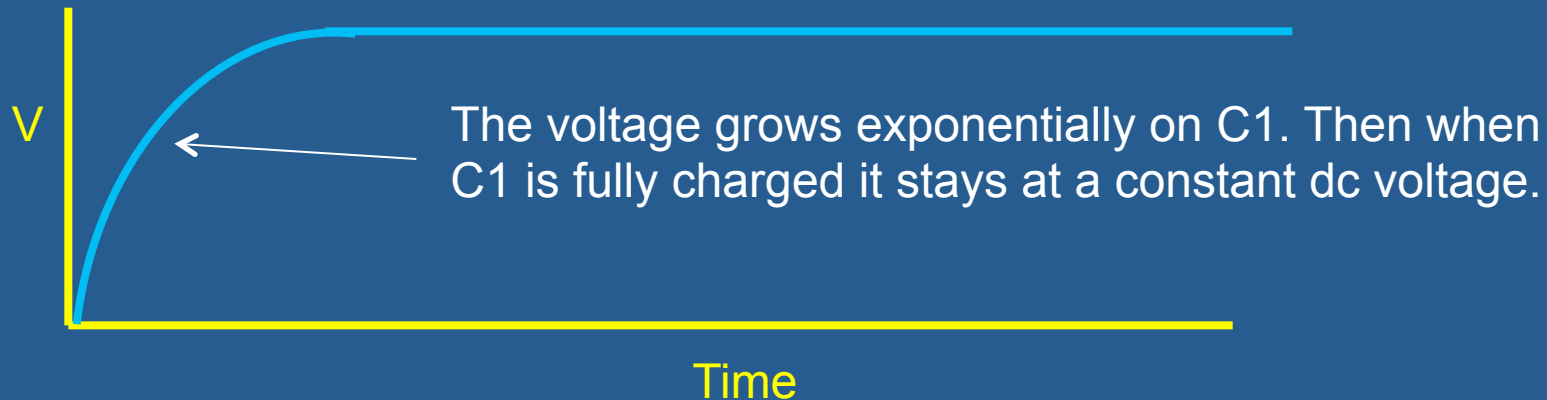

Reservoir Capacitor – Load Conditions

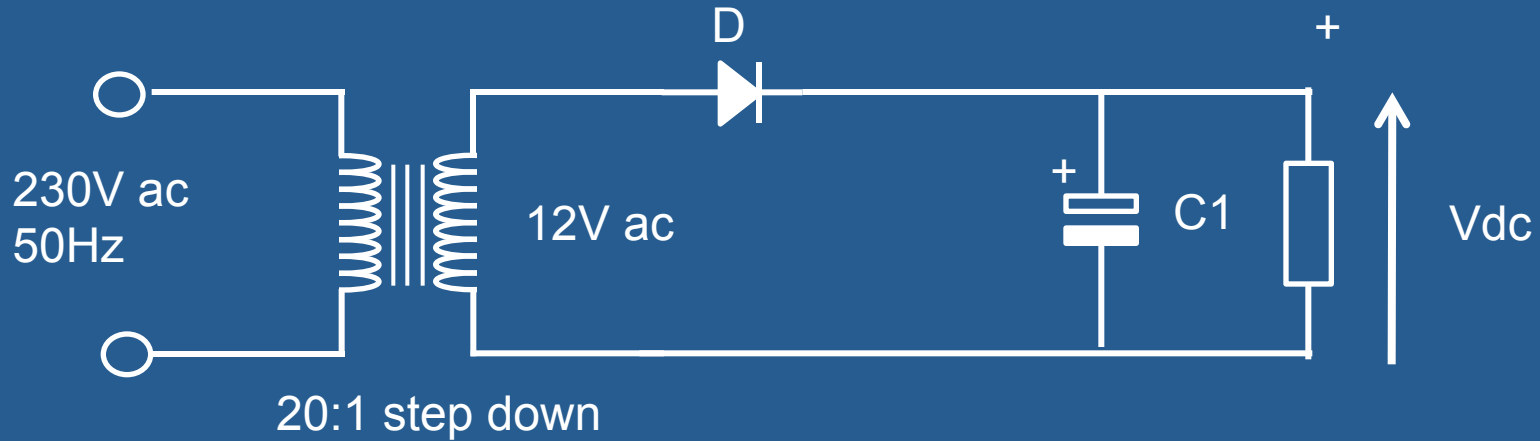

Dc output has a ripple on it (50Hz) as C1 charges and discharges



This time there is a load to be supplied with current. To do this during the period that the diode is not conducting C1 has to give up some of its charge to the load. Its terminal voltage will fall as it loses charge. (Water level in the cistern). A bigger reservoir capacitor will produce less ripple. (There is a limit though)

Full-Wave Rectification

In the previous examples we “threw away” half of the ac waveform. (The negative going half). There is nothing “wrong” with this half of the wave – it’s simply reverses its polarity.

This is obviously inefficient.

A rectification process that used both the positive going and the negative going half cycles would be an efficient process.

It would also not place such demands on the reservoir capacitor, In a system that used both half cycles the reservoir capacitor would be charged at twice the frequency. This would halve the time it is discharging so that as a consequence its terminal voltage would not drop as much.

The Full-Wave Rectifier: The Bridge

The first arrangement is known as a bridge rectifier. It comprises four diodes. Usually these come as a single, encapsulated component.

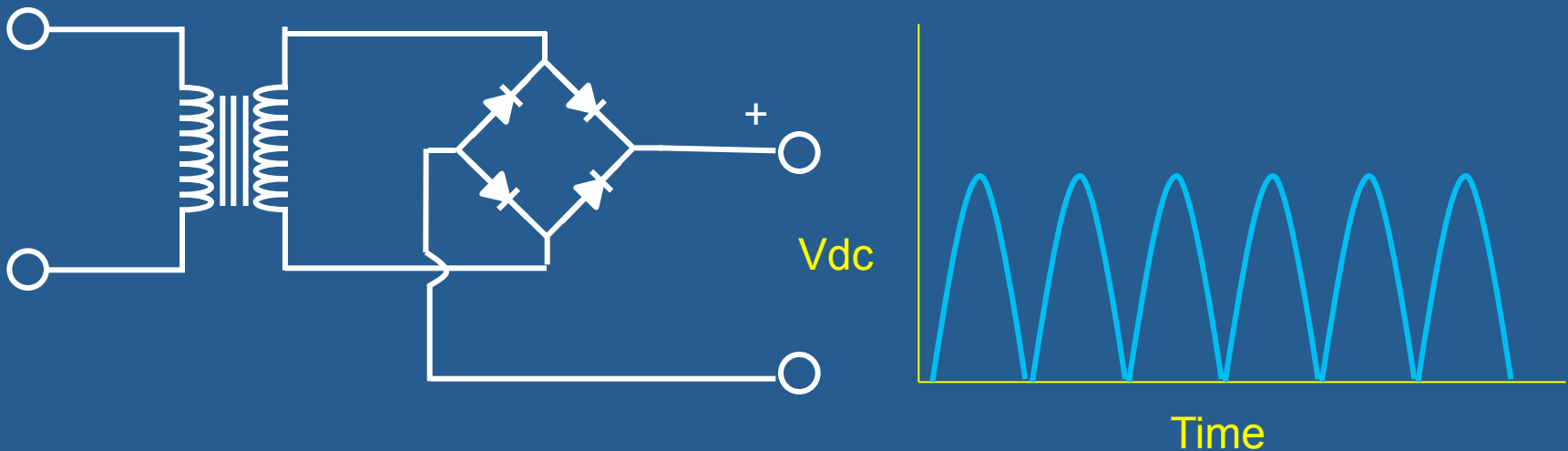

The diodes steer the pulses to the output terminals of the bridge to allow the negative half of the wave to be used.

Full-Wave: Bi-Phase

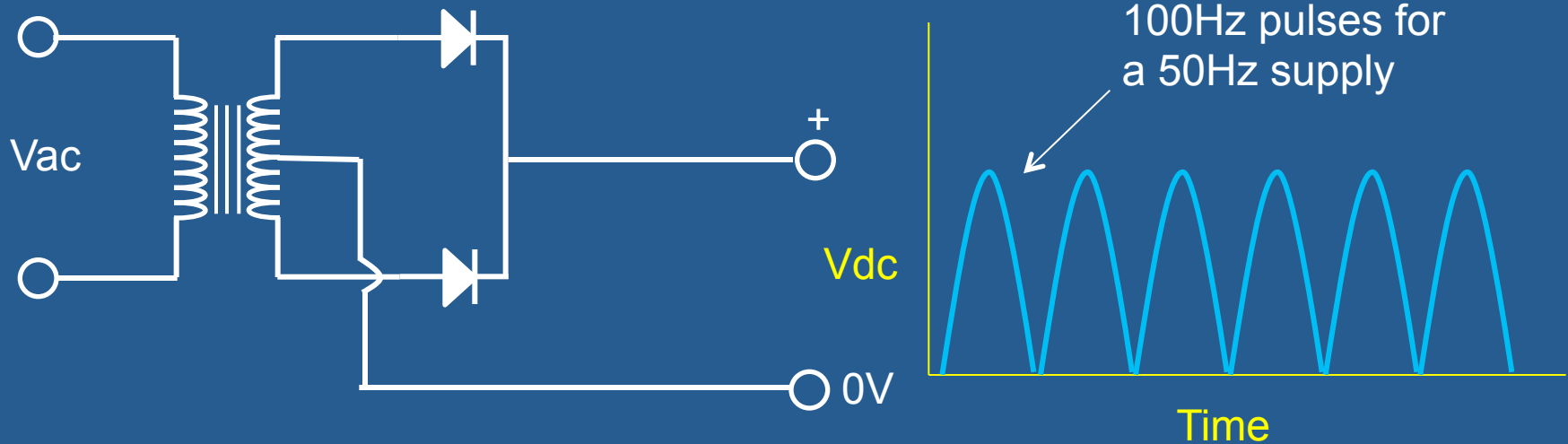

The output waveform is the same as the bridge rectifier waveform. Although it only uses two diodes the transformer now has two, secondary windings.

The point at which the two windings are connected forms the $0V$ line.

Placing a reservoir capacitor across the output will eliminate the pulses to a greater or lesser extent depending upon the load conditions. The depth of the ripple voltage is determined by how much current the load draws.

The Light Emitting Diode (LED)

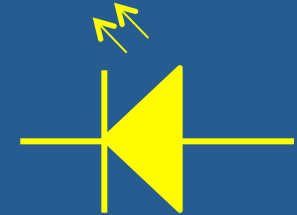

The led is a semiconductor diode. It shares the same basic characteristics of semiconductor diodes. (anode, cathode, forward conduction , etc)

However, when forward biased, it will emit light (leds can also be obtained that emit infra red or ultra violet. Their output is in or near the visible part of the spectrum.)

Unlike rectifier diodes a light emitting diode is more “electrically fragile”. They cannot tolerate excessive reverse bias and are relatively easy to destroy if you don’t take care of them.

Leds are thus usually supplied only with dc. They are also protected by a series resistor to limit the forward bias current.

LED Biasing Example

You want to use an led as a “Power On” indicator. The supply is 12 Volts dc.

The supplier’s data sheet shows an led with the following characteristics:

Forward Voltage Drop is 2 Volts at a current of 20mA.

What value of protection resistor (R) do you need?

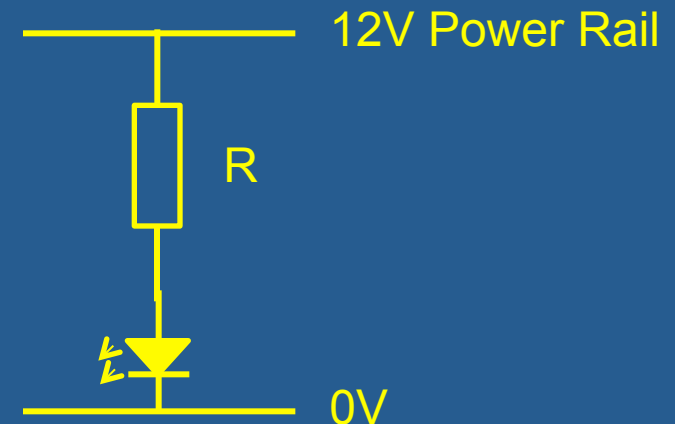

LED Biasing Example

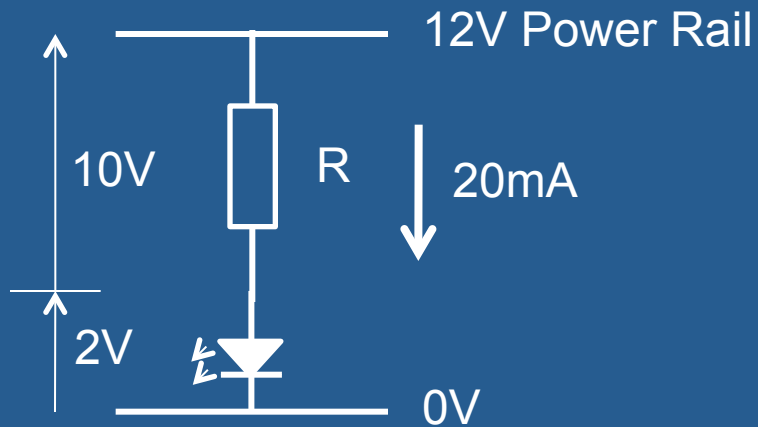

1. When conducting the led develops 2 Volts across it.
2. This leaves $(12 - 2)$ Volts to be dropped across the protection resistor R

3. From Ohms law you know that $V = I \times R$.

So: $10 \text{ Volts} = (0.02 \times R) \text{ Volts}$
 $R = (10 / 0.02) \text{ Ohms}$
 $R = 500\Omega$

The nearest preferred sizes are 470Ω or 560Ω .

Probably choose 560Ω

Variable Capacitance Diode (Varicap)

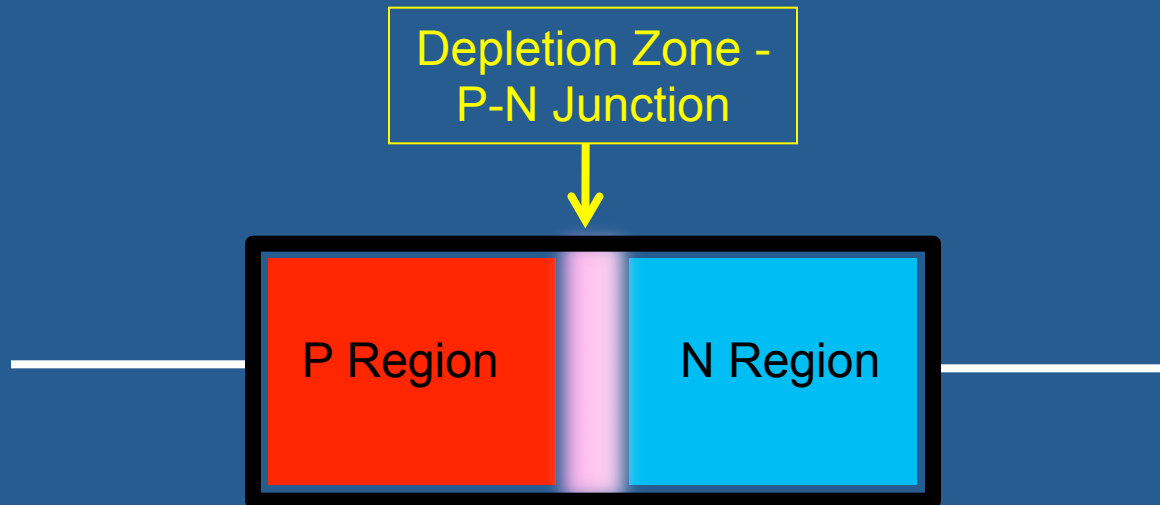

This is a representation of a P-N Junction Diode. It is very simplistic and the real life P-N Junction is far more complex and subtle. The transitions to the junction and the P and N regions are not abrupt. With all these caveats in mind the diagram does help to explain qualitatively what happens.

The unique feature of the diode is the junction or depletion zone. Here the two, doped regions merge. The N-type – with its excess of electrons and the P-type with its excess of holes. (Lack of electrons.) In this area the holes and electrons combine to form a zone with very few free charge carriers - the PN - Junction.

Varicap Diode

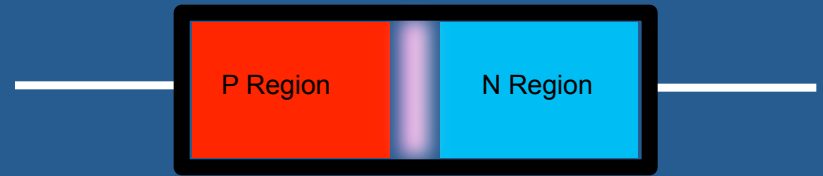

When the diode is forward biased the depletion zone shrinks. (This is because you are injecting carriers into the diode from the power supply.) This reduction in the depletion layer causes the diode to conduct. When the diode is reverse biased you are increasing the width of the depletion layer. Its resistance rises and it will not conduct. The diode blocks.

The junction looks like a plate capacitor. The area of the plate is determined by the physical and mechanical construction of the diode. The depletion layer is a variable-width, dielectric filling between the plates. As the depletion layer varies in extent it alters the distance between the plates and hence the capacitance of the junction.

The more you reverse bias the diode the further apart the plates become and the capacity will fall. Conversely, the nearer the diode comes to conduction the closer are the plates and the higher the capacity.

Varicap Diode: Bias Effect

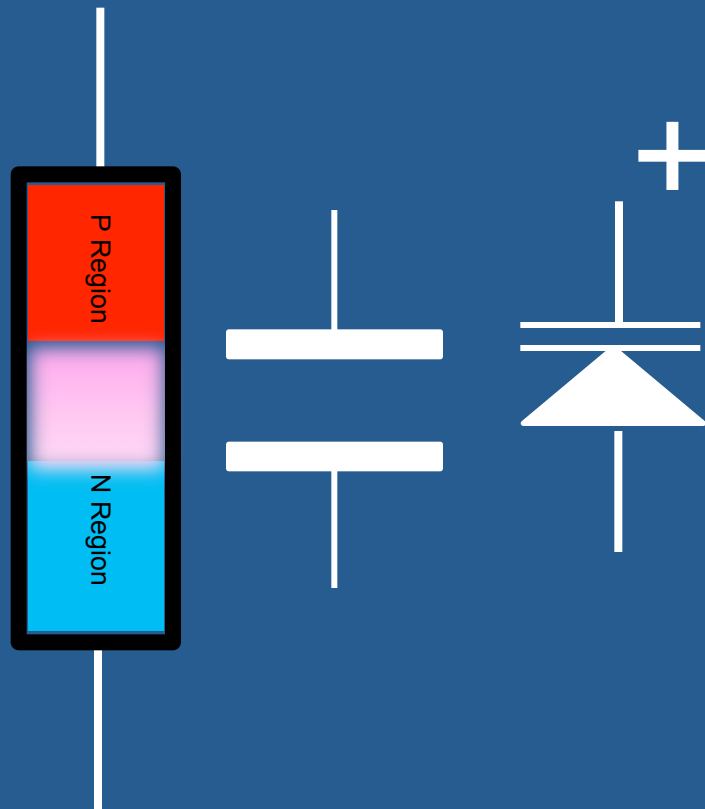

Large reverse bias applied to the diode. Big depletion layer and small capacitance

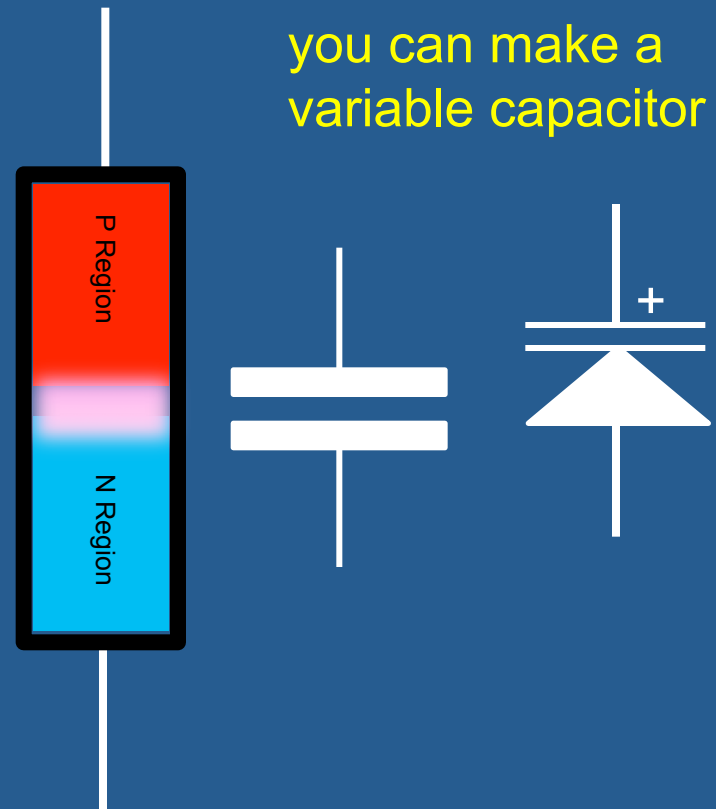

Small reverse bias applied to the diode. Small depletion layer and large capacitance

Thus by varying the reverse bias you can make a variable capacitor

The Bipolar, NPN Transistor

The transistor is a three-terminal, semiconductor device. It can be made to operate in two ways:

- As a solid-state switch;
- As an amplifier.

The device terminals are called:

- The Collector; (c)
- The Base; (b)
- The Emitter (e)

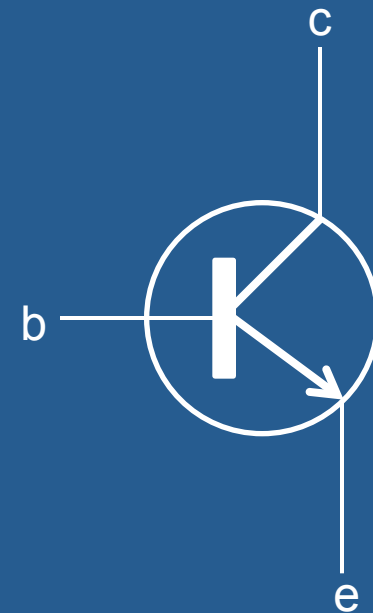

The base terminal is used to control the flow of current through the device.

Simple Model

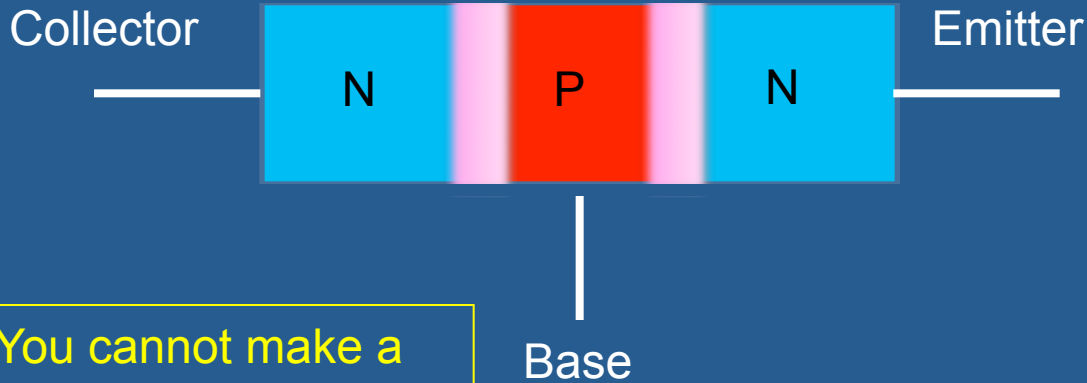

You cannot make a transistor out of two, back-to-back diodes!

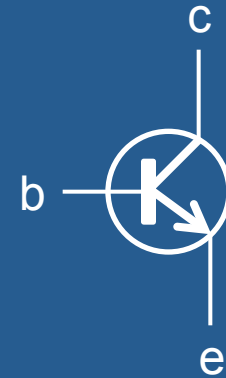
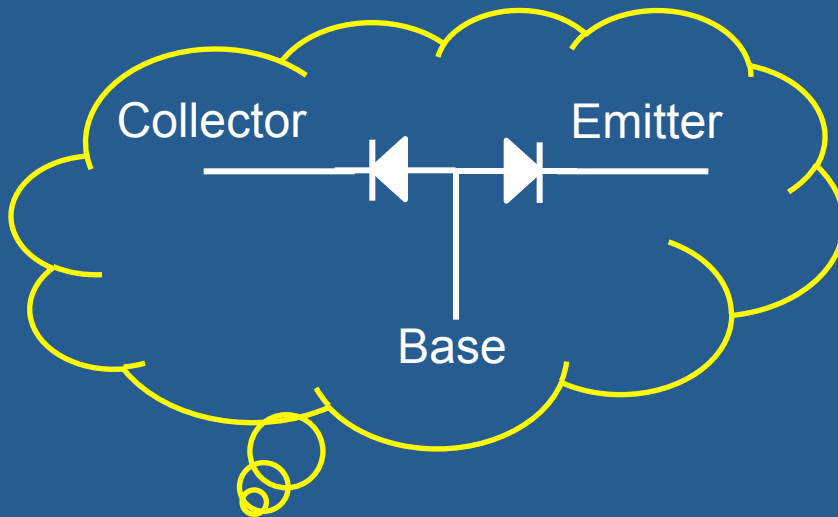

Circuit Symbols

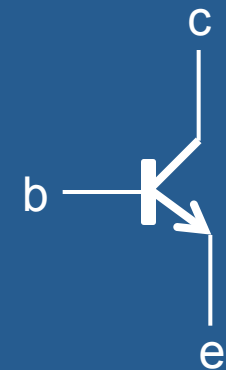

NPN Transistor: Mechanical Analogy

A water valve provides a reasonable analogy to how the transistor operates. By varying the opening of the valve you control the flow through it. A very small amount of effort on the valve's hand-wheel can control a large flow of water. A small injection of current into the transistor base will control a relatively large flow of current between the collector and the emitter. Rapidly opening the valve to full on is like a switch. Gradually opening the valve progressively increases the flow.

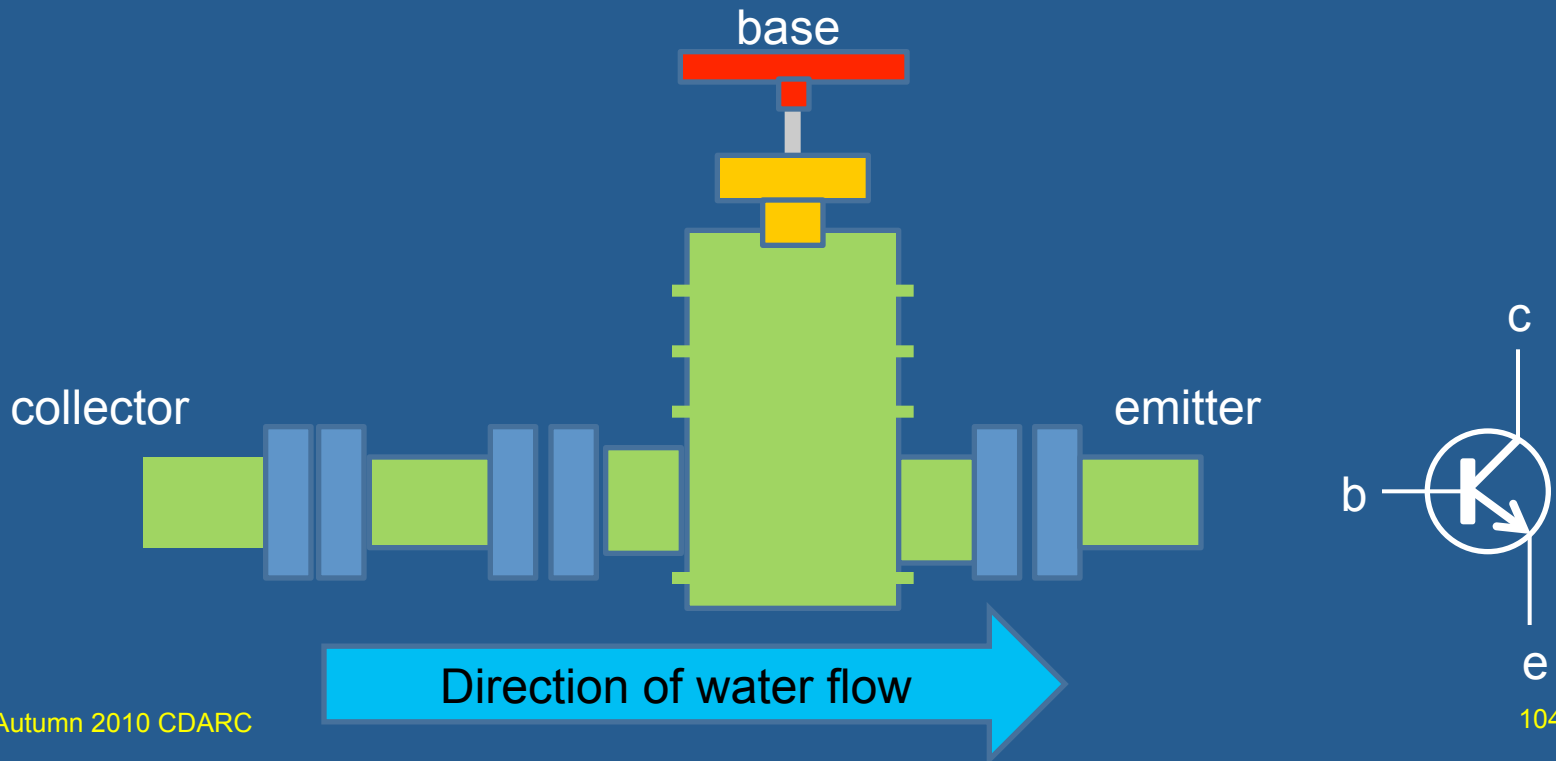

Mechanical Analogy Continued

Let's say that the valve hand-wheel has 10 turns from fully closed to fully open. The first couple of turns serve to lift the valve off its seat so the flow is only a bit of a trickle by the time you get to 2 turns open. Turns 2 to 8 allow the water flow to increase linearly. Turns 8 to 10 on the hand-wheel have little further effect on the volume of water going through the valve.

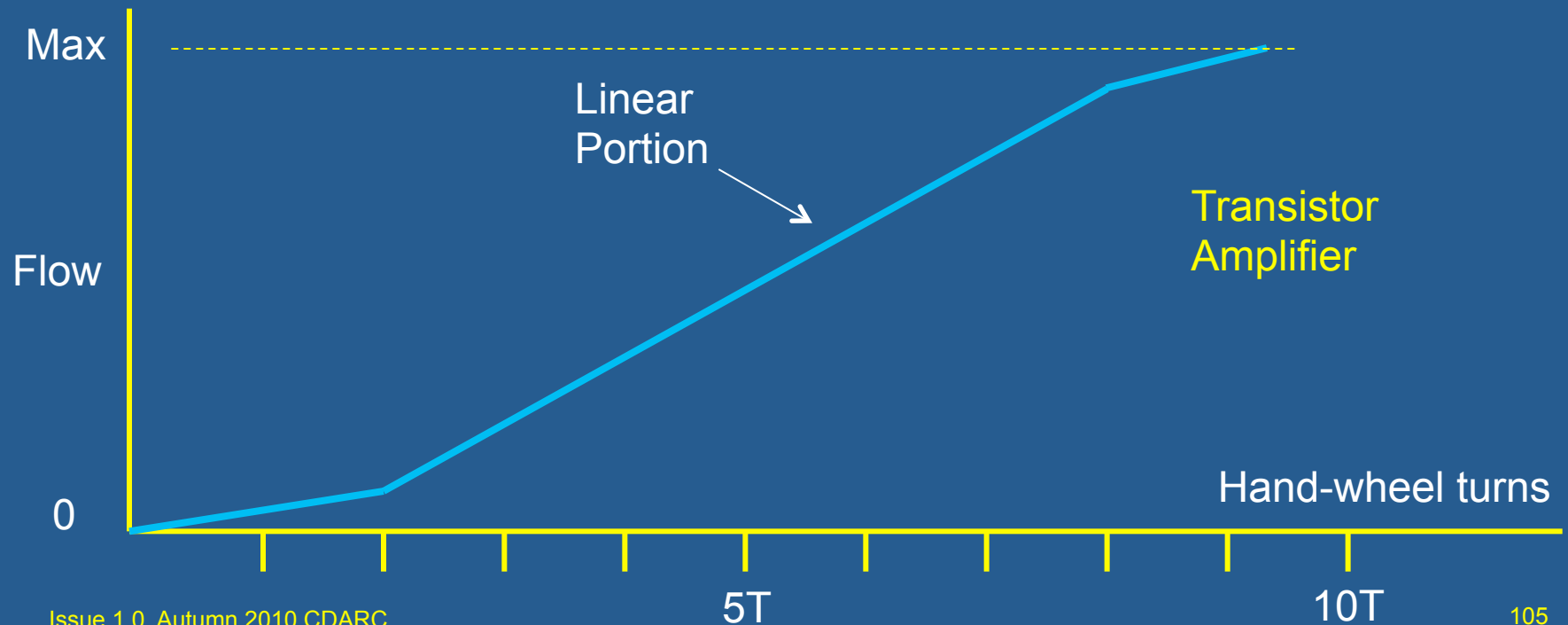

Mechanical Analogy

Suppose now that our water valve develops a fault. Instead of a smooth transition between turns 2 to 8 the valve jumps to fully open once you reach 2 turns, The transfer characteristic will now look as follows. It now has the characteristic of a switch. It is either fully off or fully on. Once you are past 2 turns the valve avalanches on.

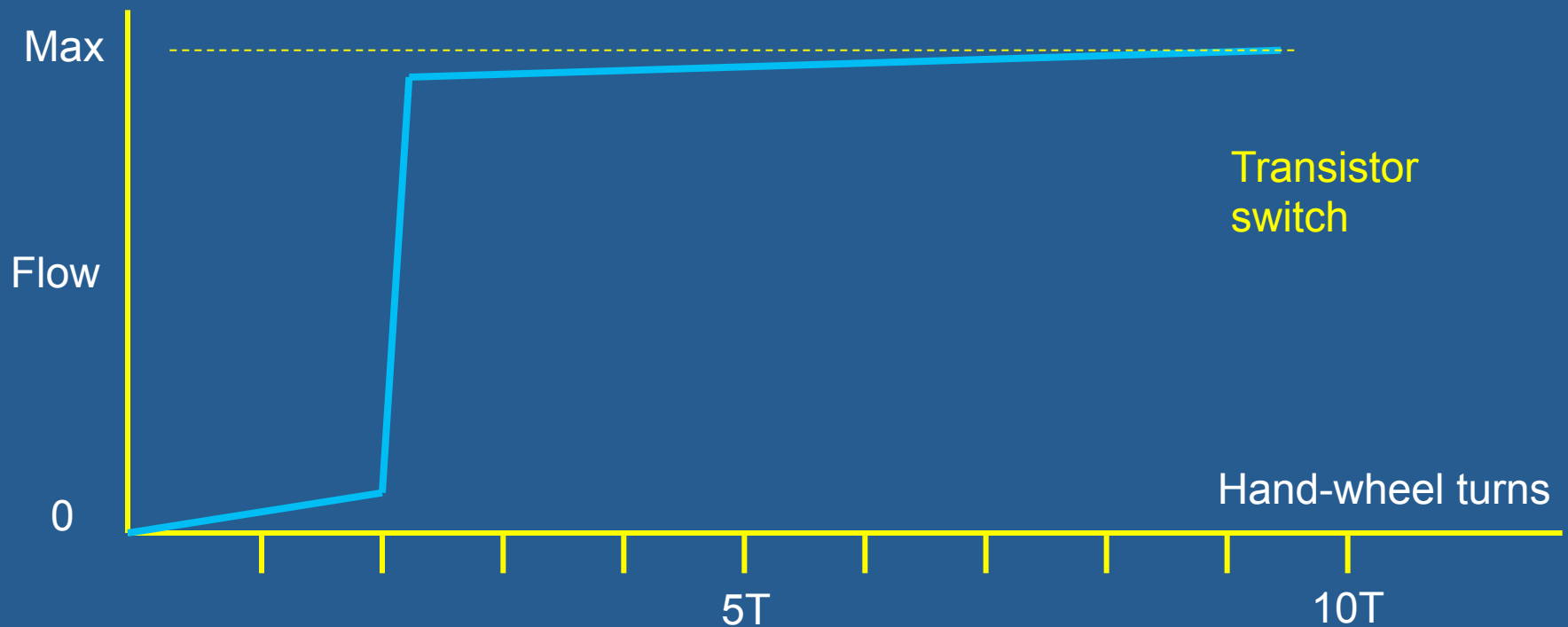

NPN Transistor Common Emitter Amplifier

V_{in} is the input to the amplifier. The base of the transistor sits at a defined dc voltage provided by the potential divider R1 and R2. Capacitor C1 blocks this dc voltage from getting back to the signal source. The operating point of the transistor places it half way up its curve on the linear portion. R3 and R4 are used to set the collector current and the operating point. The transistor has a current gain. (β). Any small change in the base current going into the device is amplified by this value β . The collector current will be an amplified version of the base current (signal input) and appears across R3. The amplified signal is taken out via C2 (blocking capacitor).

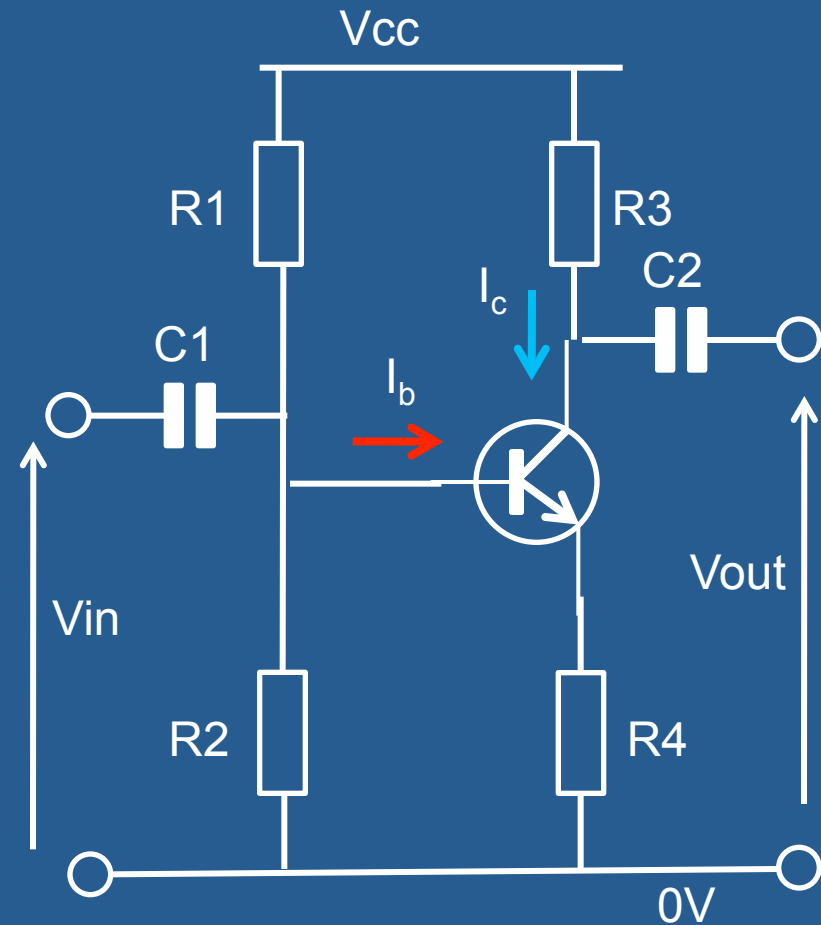

$$I_c = \beta \times I_b$$

NPN Transistor Switch

The transistor can also be made to operate as a switch.

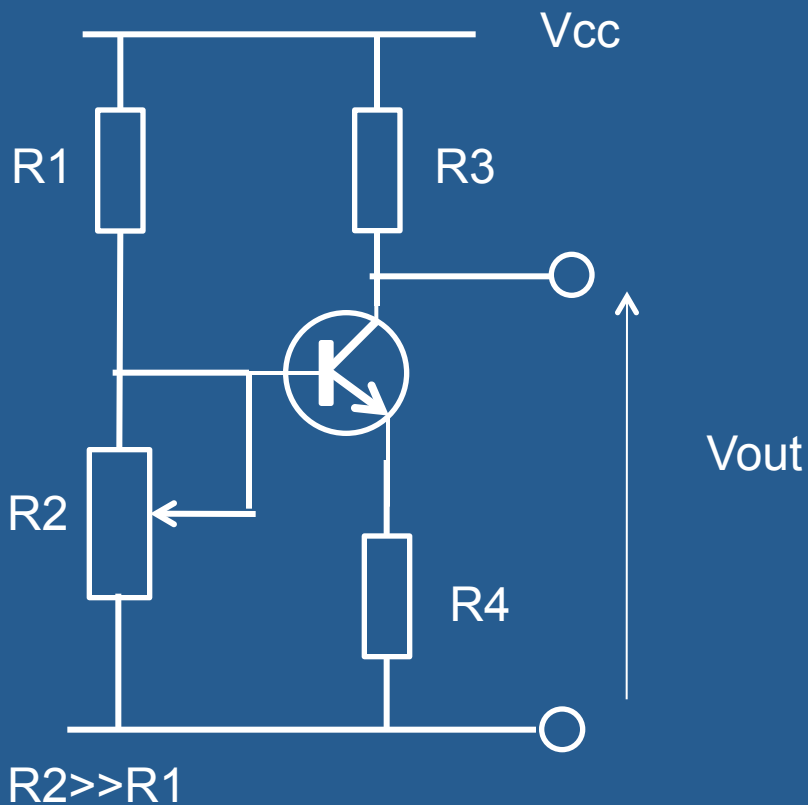

R2 is a variable resistor. By varying the value of R2 the voltage at the base of the transistor can be varied between 0 Volts and the voltage present at the junction of R1 and R.

As the base voltage moves closer to Vcc the base current and hence the collector current will increase.

Eventually the collector current becomes so large (relatively) that the transistor “saturates” and no further increase in collector current occurs with an increase in base voltage. The transistor is now turned fully on and the collector voltage is low.

Transistor Oscillator

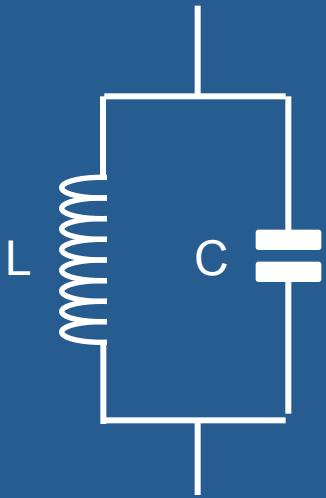

A parallel
tuned circuit

The circuit has a natural resonant frequency.

This frequency is determined by the values of L and C.

The equation for calculating the frequency is:

$$f = \frac{1}{2\pi\sqrt{LC}}$$

Where L is in HENRIES and C is in FARADS

Transistor Oscillator

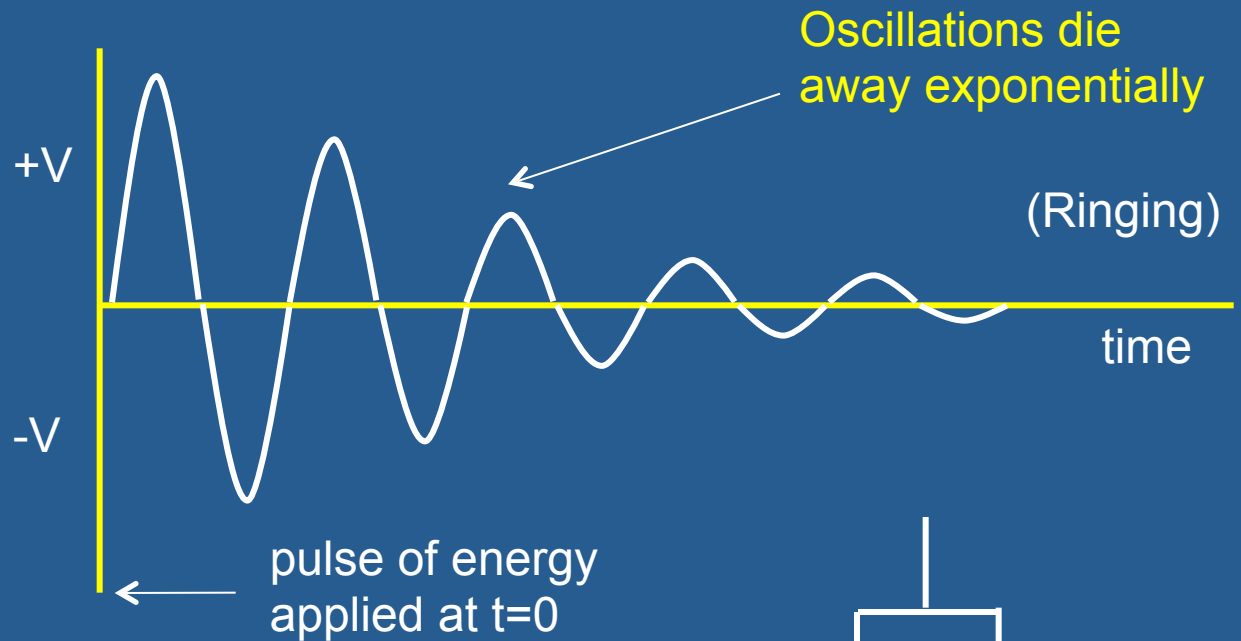
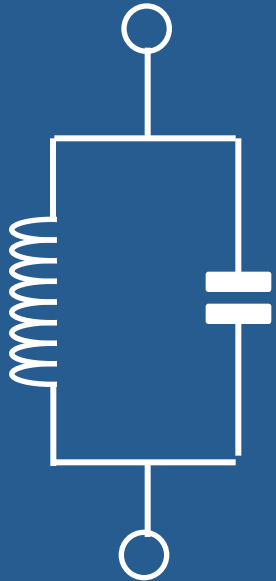

In practice the oscillations die away because the circuit has intrinsic resistance. (coil winding resistance). The energy which was originally stored magnetically in the coil and electrostatically in the capacitor is dissipated as heat in this unavoidable resistance. When winding coils for tuned circuits you should aim to use wire of the lowest, practical resistance.

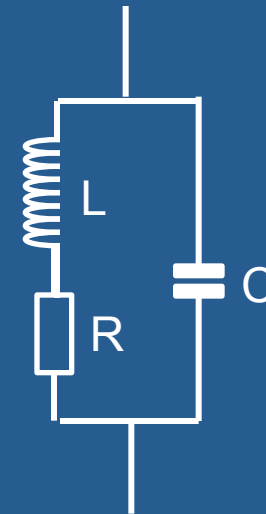

Transistor Oscillator

What we need is some means of counteracting this loss of energy through the circuit resistance. If we can do this then we can sustain the oscillations indefinitely. By choosing our values for L and C we can tailor the frequency to produce a practical oscillator.

By using a transistor to provide gain to overcome the losses the tuned circuit will provide the core element of an oscillator.

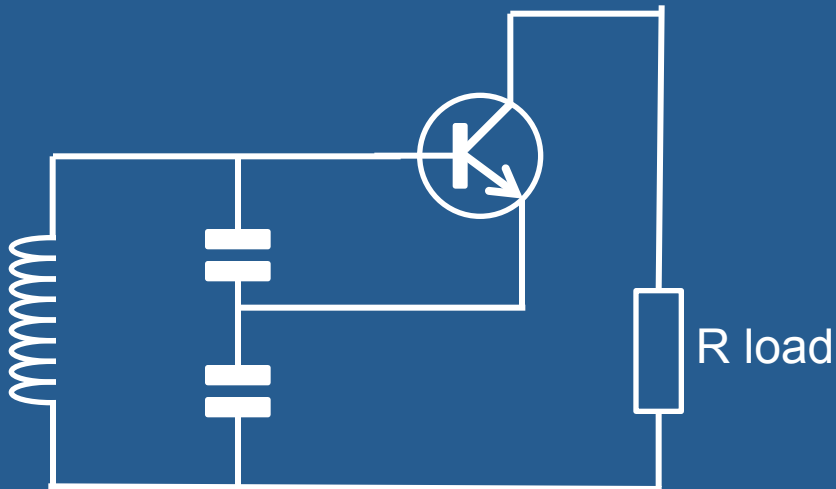

The transistor makes up for the resistive losses. It provides positive feedback to the tuned circuit to keep it resonating.

Colpitts Oscillator – Practical Circuit

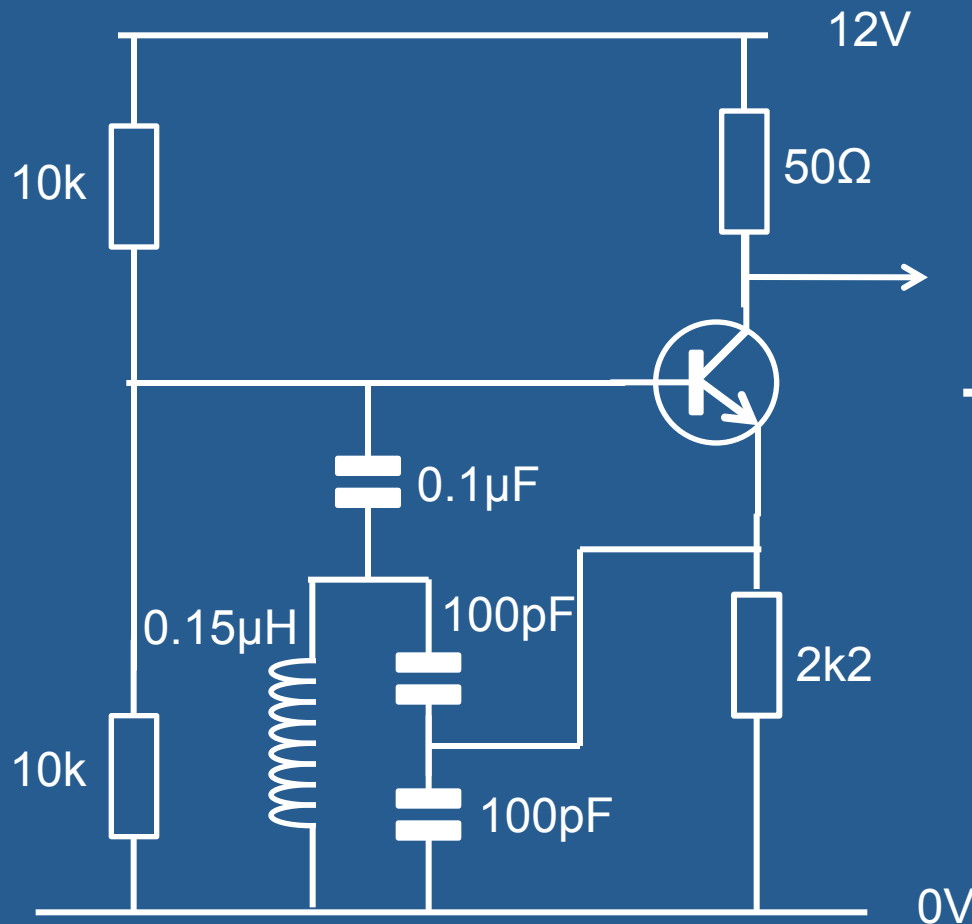

$$f = \sqrt{L1 \left\{ \frac{C1 \cdot C2}{C1 + C2} \right\}} \cdot 0.159$$

~ 50MHz

Crystal Oscillator

A crystal oscillator makes use of the piezoelectric effect.

The piezoelectric effect is an electro-mechanical property of a crystal. Under an applied voltage the crystal lattice will shift or distort. (mechanical effect). Conversely a mechanical displacement of the crystal will cause a voltage to appear across opposite faces. (electrical effect).



The crystal behaves like a mechanical tuning fork and a tuned circuit

If the crystal (generally quartz) is cut and mounted properly it will oscillate at a precise frequency.

Crystal Oscillator

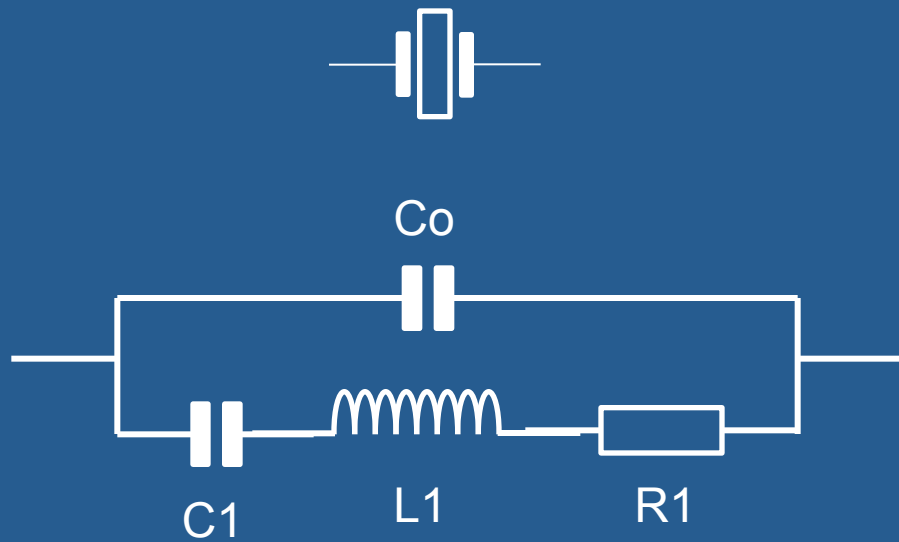

Equivalent circuit of a crystal oscillator.

Colpitts Crystal Oscillator

C1 and C2 are used to “nudge” the crystal frequency by compensating for inaccuracies in the crystal.

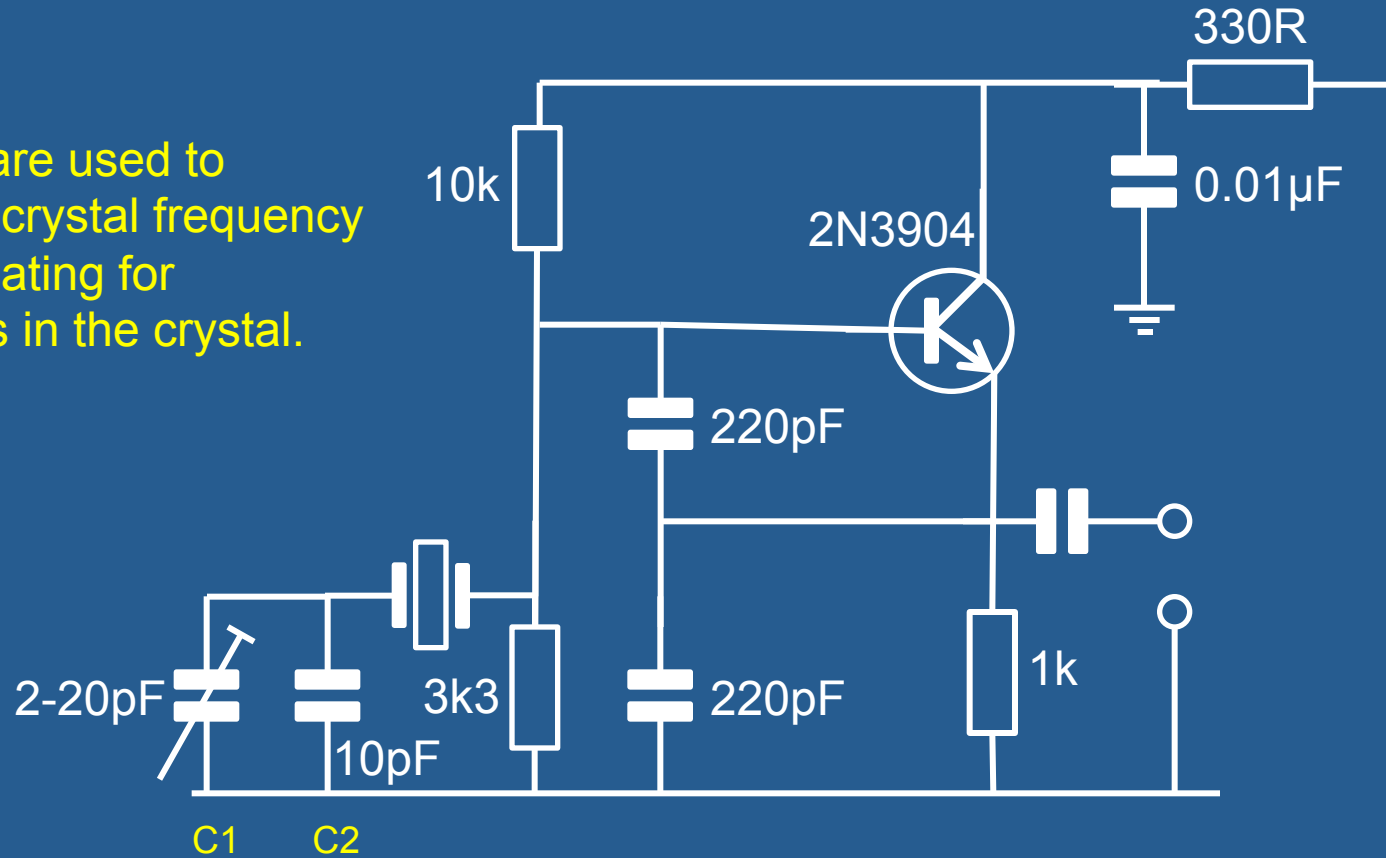

Variable Frequency Oscillator (VFO)

Measurements

The Multimeter

The multimeter is an essential piece of test gear. It may be either analogue or digital. (Nowadays finding a good analogue multimeter is difficult.)

A basic multimeter will measure Volts/Amps/Ohms. Many offer capacitance and inductance measurement as well as transistor and diode testers.

An ideal multimeter will present an infinite resistance when measuring voltage and zero resistance on its current ranges. This will allow it to make measurements without loading the circuit under investigation.

All practical voltmeters fall short of this ideal. However a reasonably priced model will approach these ideals and be more than sufficient for our purposes.

Measuring With The Multimeter

Voltage: This is an “across variable”. That is the voltage appears across a component or circuit. You measure the voltage between two points. The voltmeter goes in parallel with the component or element. Always start with the voltmeter on its highest voltage range. Then select the voltage range which will display the voltage measured to the precision you require within the upper limit of the range. (It is good practice not to change range with the meter in circuit in case the range change switch shorts momentarily as it commutes round.)

Current: This is a “through variable”. You measure the current through a circuit element or component. The ammeter goes in series with the component or branch of the circuit being measured. Always start with the highest current range first for the initial measurement. Then reduce the range to the one which will accommodate the reading to the precision you require.

Measuring Ohms

Do not put the ohmmeter in the ohms range across a circuit element with the circuit energised. You will damage the meter.

Ideally you should remove the item or element out of circuit completely and discharge any stored voltage before measuring.

Semiconductor devices can give strange readings as they are polarised devices and may be reversed biased by the meter which has a battery in it.

The ohmmeter is a voltage source in series with an ammeter. The unknown resistor completes the circuit. The ammeter is calibrated to read ohms instead of amps. (Remember current is linearly related to resistance.)

Analogue Versus Digital Multimeters

There are pros and cons between the two types. This is similar to digital and analogue watches.

Digital (Pros)

- Easy to read;
- Handles reverse polarity easily in the dc ranges;
- Can be auto-ranging to select the optimum range setting.

Digital (Cons)

- Difficult to estimate a percentage change or peak reading at a glance

Ideally have one of each!

Digital Versus Analogue Multimeters

Analogue (Pros):

- Can see at-a-glance the rough value of a reading by the position of the needle on the scale - $\frac{1}{4}$, $\frac{1}{2}$, $\frac{3}{4}$, of the full-scale deflection.
- Small changes are easy to see – especially if you are “peaking up”

Analogue (Cons):

- Easy to mis-read non-linear scales.
- Does not handle reverses of polarity in the dc ranges.

Importance Of Polarity

Digital Meters: This is generally not a problem with digital meters. The meter will indicate a “negative” symbol to indicate that the meter leads need to be reversed to respect the actual polarity.

Analogue Meters: In an analogue meter the needle only moves from left to right. If the meter is reverse connected then the needle will be pushed against the left-hand end stop. This can lead to the burn out of the armature coil or a bent needle.

Voltmeter and Ammeter Connection

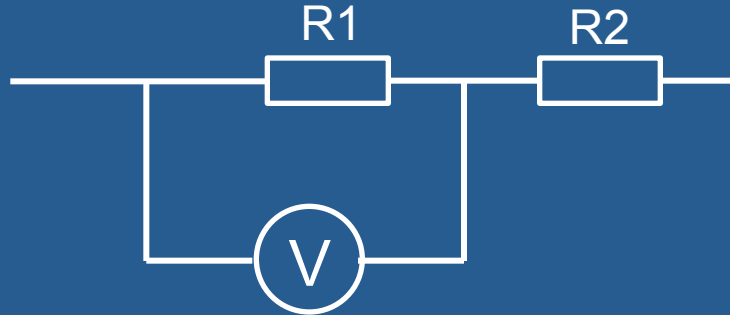

To measure the voltage *across* R1 the voltmeter is connected across the resistor in parallel with it.



To measure the current *through* R1 the ammeter is connected in series with it.

Current Through A Series Circuit

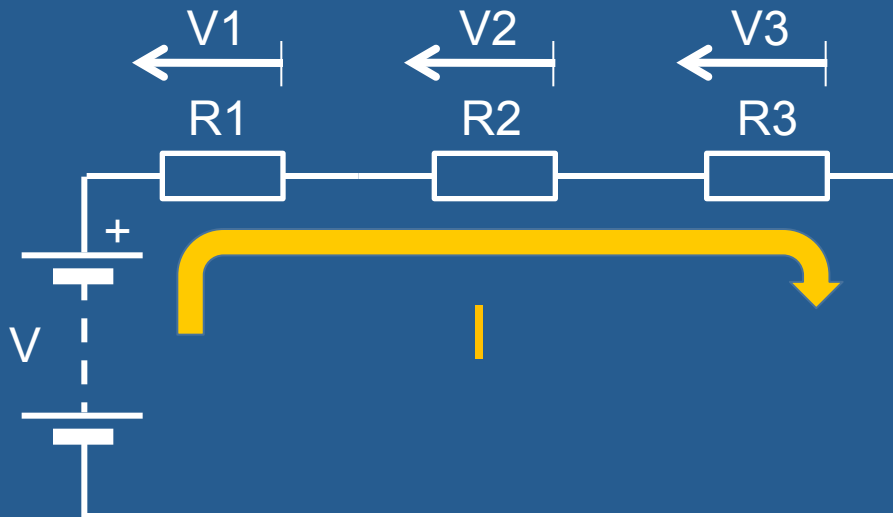

In a series circuit the current (I) passes through each of the elements. The current is common to every element.

Voltage Across Parallel Components

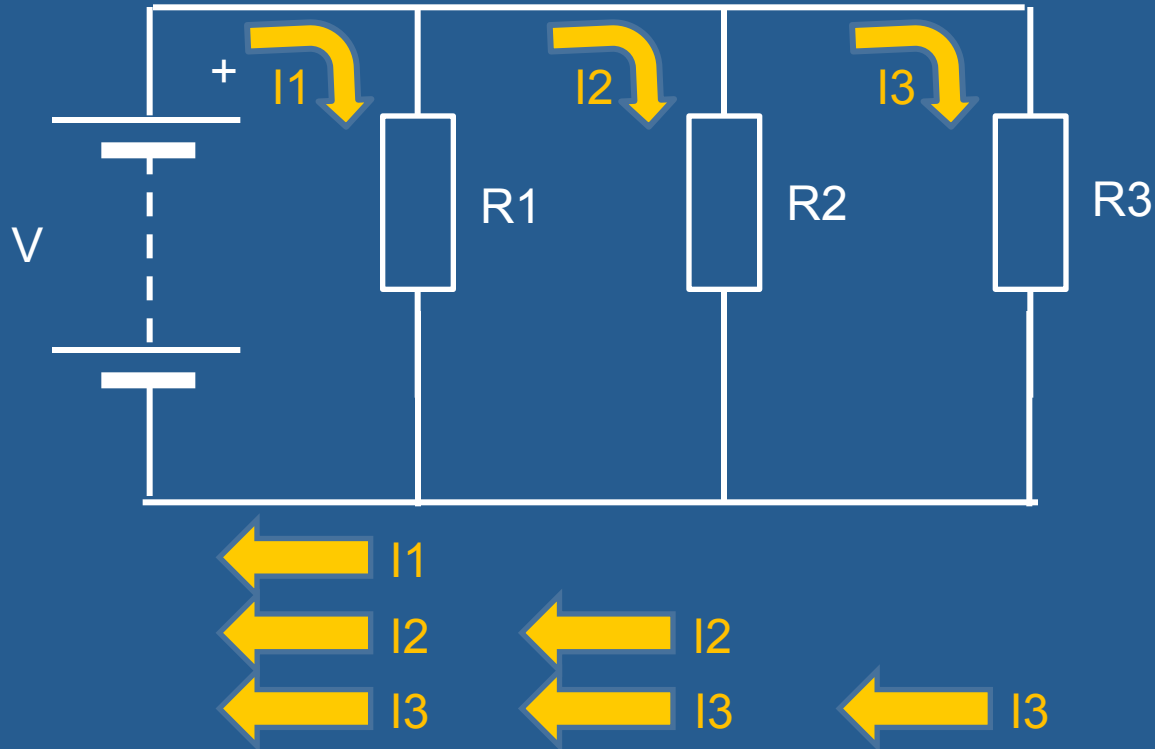

In a parallel circuit all of the components appear across a single voltage source. They all experience a common, identical voltage across them.

Series And Parallel

Series Circuit: Shares a *common current*.

Parallel Circuit: Shares a *common voltage*.

Measuring dc Power



A voltage source V drives a current I through a load resistance R . The current flowing through R will dissipate power in this resistance.

Ohms law links V , I and R by the relationship $V = I \times R$

The Power (W) dissipated in R is given by $W = I \times V$

By measuring the voltage and current at the load resistor you can calculate the power that the resistor is dissipating.

Measuring The Power

You can calculate the power dissipation in a number of ways.

The basic relationship is, as previously, $P = V \times I$

You know from Ohms Law that $V = I \times R$

Replacing V with $(I \times R)$ in the basic power equation you can rewrite it as:

$$P = I \times (I \times R)$$

$$P = I^2 R$$

Or, knowing that $I = V / R$, you can similarly replace I with (V / R) to get

$$P = V \times (V / R)$$

$$P = V^2 / R \quad \text{(Useful if you know } R \text{ and either } V \text{ or } I \text{ but not both.)}$$

Power Worked Example

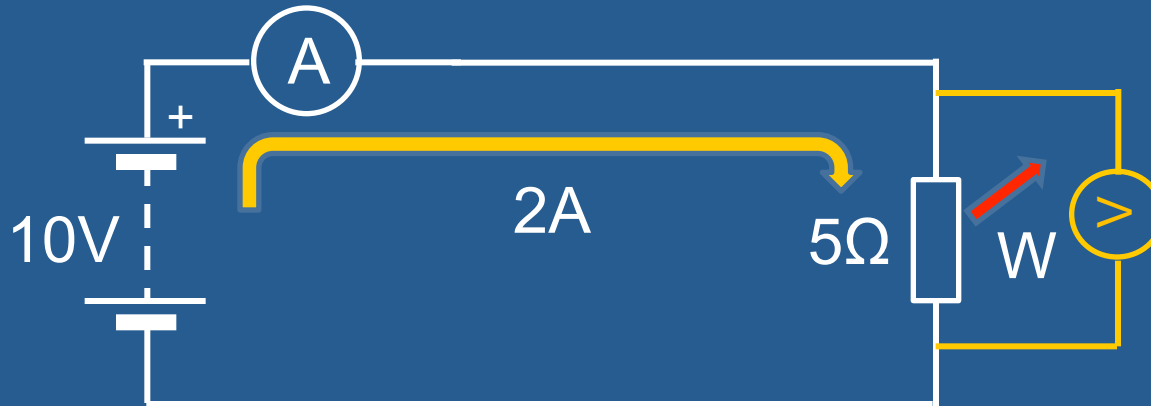

$$P = V \times I;$$

$$P = (10 \times 2);$$

$$P = 20 \text{ Watts}$$

$$P = I^2 \times R;$$

$$P = (2 \times 2 \times 5);$$

$$P = 20 \text{ Watts}$$

$$P = V^2 / R;$$

$$P = (10 \times 10 / 5);$$

$$P = 20 \text{ watts}$$

dc and RF Power

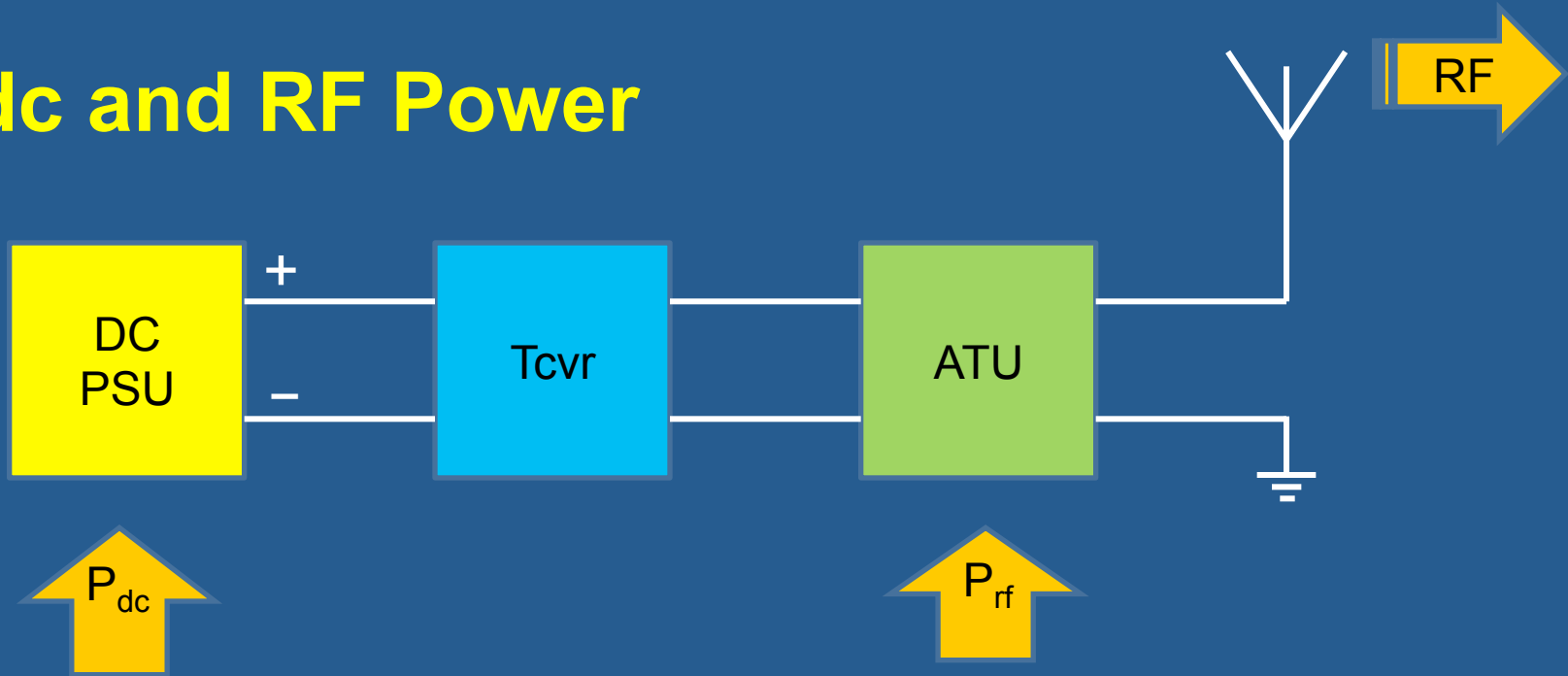

The dc power (P_{dc}) that you measure at the dc Power Supply Unit (PSU) is always greater in value than the RF power (P_{rf}) that you measure at the ATU that is being delivered to the antenna.

There are always losses in the system. These are the ohmic losses in the wire, feeders and ATU. As the frequency increases the losses in the feeder – particularly coaxial feeder – also increase. The transmitter is not 100% efficient. An efficiency of 50% is not uncommon. (ie for every 2W of dc power provided 1W of RF power will be produced with 1W dissipated as waste heat at the Tx.

Transmitter Block Diagrams

CW Transmitter

AM Transmitter

SSB Transmitter

FM Transmitter

Function Of The Microphone Amplifier

AM / FM Modulator

Balanced Modulator For SSB

The Side Band Filter

The RF Oscillator

The RF Power Amplifier

The Low Pass Filter

Relative Merits Of The Crystal And The VFO

Crystal: (Pros)

- Easy to set frequency;
- Less prone to drifting.

Crystal: (Cons)

- Single frequency (with a minimum amount of adjustment);
- Crystals can be expensive for non-preferred values;
- Standard range values only are generally available. (Non-standard are expensive)

VFO (Pros)

- Cheap to build;
- Large frequency range is possible.

VFO: (Cons)

- Prone to temperature drift;
- Need to be calibrated.

The Frequency Of The VFO

The tuned circuit in the VFO determines the frequency of oscillation.

Oscillator Stability: Mechanical

Mechanical Stability: The components in an oscillator have mutual inductance and capacitance. This is an inescapable consequence of their physical size and relative positions. They will mutually couple and interact with each other.

Any mechanical vibrations (for example tapping the oscillator circuit board or the screened enclosure.) will set up mechanical vibrations.

Although they are of small amplitude they will cause changes in the mutual inductance and capacitance. These changes will affect the output frequency of the oscillator.

Oscillator Stability: Thermal

Thermal Stability: The component values in an oscillator will change as their temperature changes. As a consequence of this the output frequency of the oscillator will change as well.

The drift in frequency can, to a certain extent, be minimised by placing the oscillator in a temperature-controlled environment or “oven”. *(High stability crystal oscillators are often placed in a “crystal oven” which maintains the device at a steady temperature).*

Not all components vary at the same rate or in the same direction (+ / -). By careful design you can match component drifts so that as one drifts upwards in value another drifts downwards. The net effect can be a degree of neutralisation which helps the thermal stability.

Oscillator Stability: Screening

Placing the oscillator circuit in a screened, metal enclosure will help to isolate it from the effects of other circuit elements. These elements may themselves be oscillating and producing local RF. This can couple into the oscillator circuit and cause instability.

Oscillator Stability: regulated dc Supply

A stable, regulated and constant dc supply is essential for good oscillator stability. Usually the system is supplied by a common, dc rail. This can provide a conduit for all sorts of signals to travel around the system and cause interference.

Any stray signals, coupled to the supply and passed through to the oscillator have the potential to affect the oscillator stability.

Variations in voltage may cause changes in component values and semiconductor characteristics. While these may be only small changes when you are dealing with oscillators in the tens or hundreds of Megahertz a small change can represent a wide swing in RF output frequency.

Drift and Operation Outside Band Limits

An ideal oscillator will not drift and will remain at the set frequency. If it drifts it may cause its RF output to move outside the permitted band. As an extreme example:

Suppose that you are operating at 144.100 MHz and your RF oscillator drifts downwards in frequency by 0.1%. (one part in one thousand).

The new oscillator frequency will be changed by (144.100×0.001) MHz.

This will be $(144.100 - 0.1441)$ MHz which equals 143.9559 MHz

This is now outside the 2 metre amateur band.

Digitally-Synthesized Oscillators

Most modern transceivers use RF oscillators the output of which is digitally-synthesised.

Provided that the digital clock driving the synthesiser is stable then any frequency that is synthesised will share the clock stability.

By placing the clock in a crystal oven very high levels of oscillator output stability are achievable.

This is called Direct Digital Synthesis (DDS)

Mixers

A key process within the radio is the transfer of information at audio frequency onto an RF carrier. Another key process is the changing of one frequency to another with the retention of the carried information from one to the other.

This process is carried out in a circuit called a mixer.

When two frequencies are mixed together two further frequencies are produced at the output of the mixer.

Suppose that we have two frequencies f_1 and f_2 . Further let's say that f_1 is 1MHz and f_2 is 50MHz

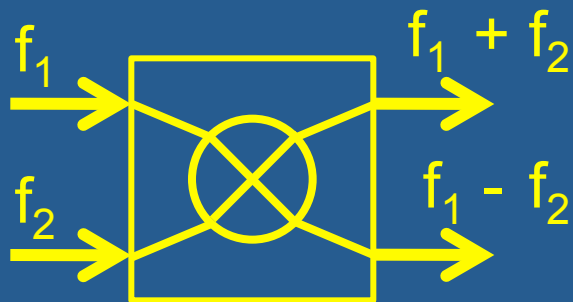

$$(50\text{MHz} + 1\text{MHz}) = 51\text{MHz}$$

$$(50\text{MHz} - 1\text{MHz}) = 49\text{MHz}$$

Modulation And Sidebands

When one of the two input frequencies is an audio frequency and the other is a radio frequency then the resulting two frequencies ($f_1 \pm f_2$) are known as sidebands.

The output ($f_1 + f_2$) is the Upper Sideband (usb)

The output ($f_1 - f_2$) is the Lower Sideband (lsb)

The next slide shows the frequency spectrum for a carrier of 1MHz and an audio signal of 1 kHz.

Spectrum Of 1MHz (f_1) and 1kHz (f_2)

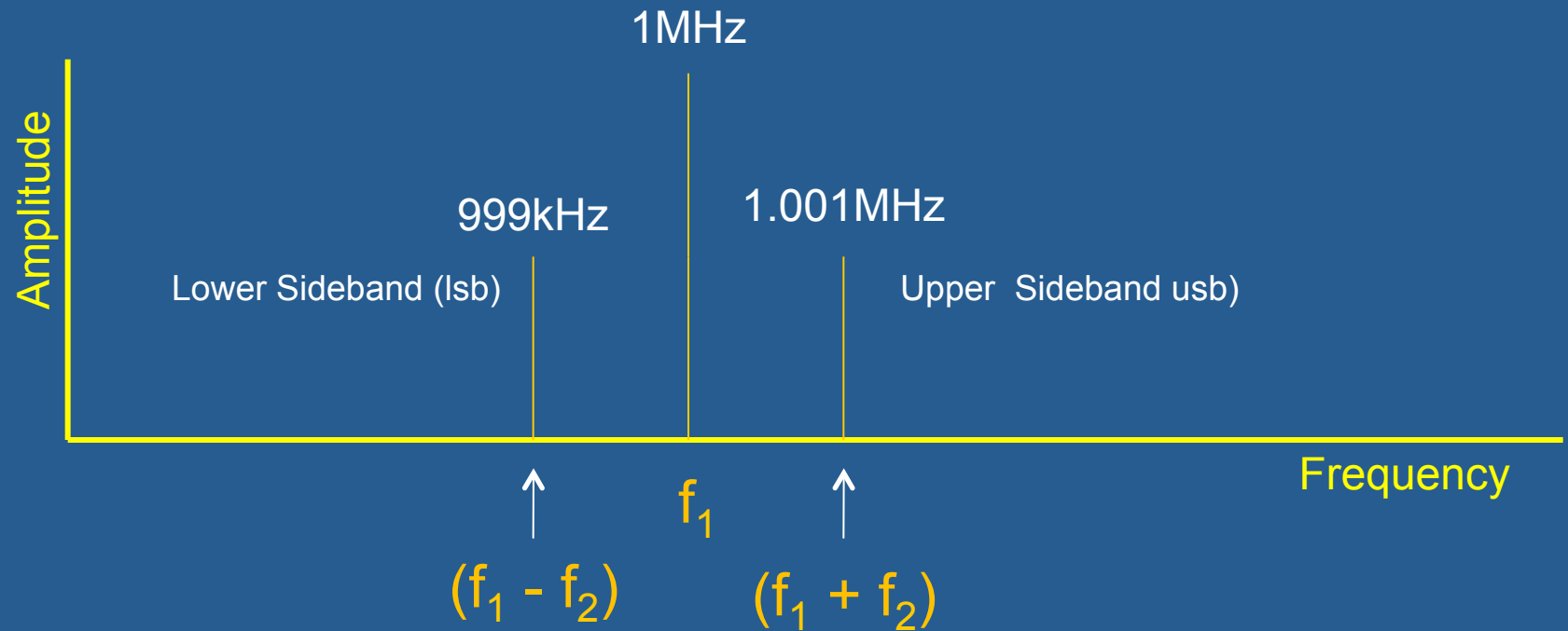

Time Domain of 1MHz and 1kHz

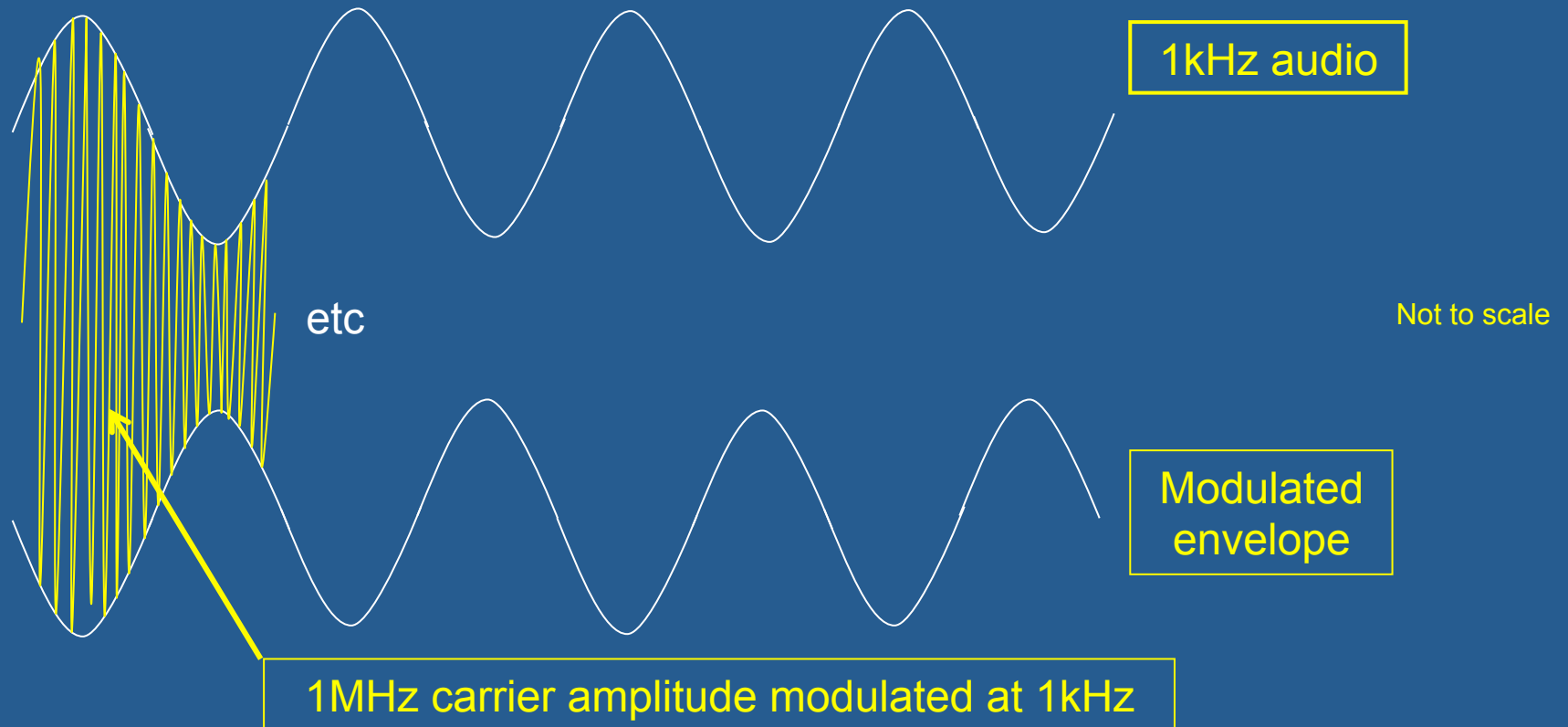

The amplitude of the 1MHz RF carrier is varying at a rate of 1kHz

Sidebands (2) Modulation and Speech

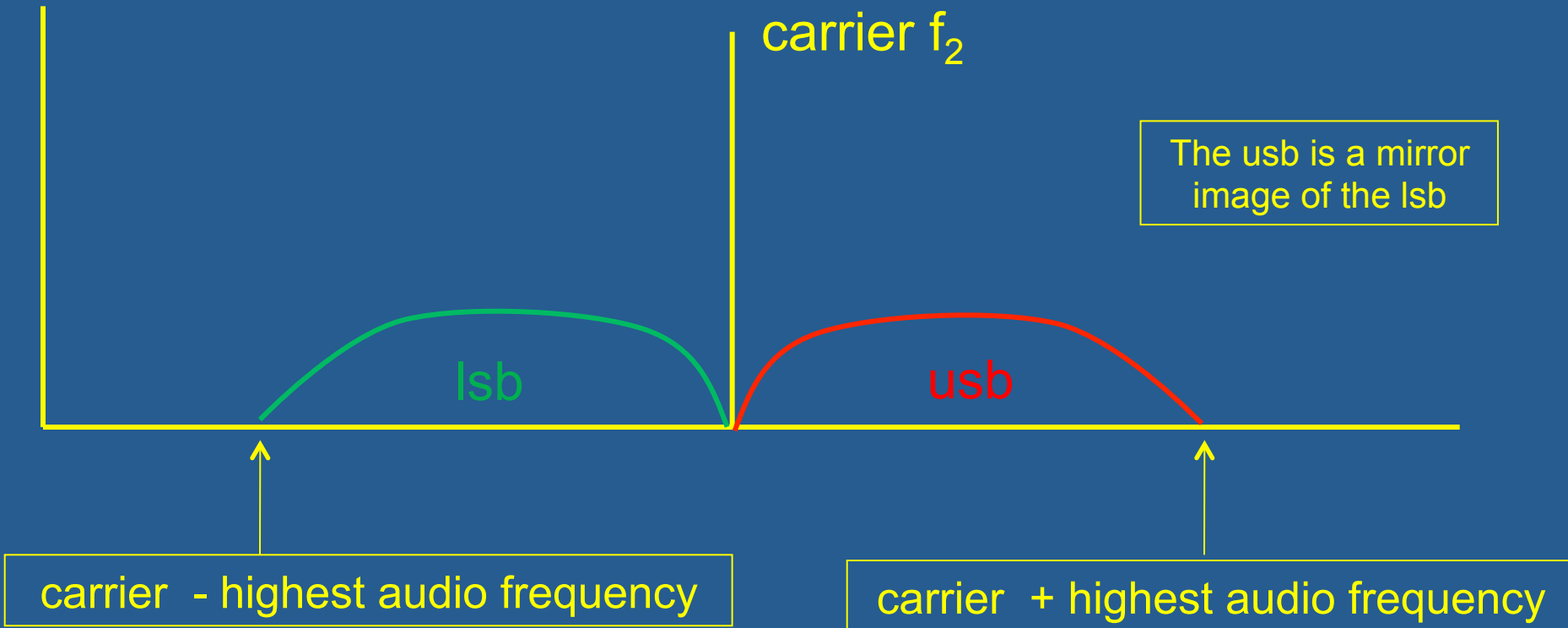

Where the modulating frequency is a continuous band of frequencies (eg speech) then the sidebands ($f_2 \pm f_1$) are also a continuous band mirroring the speech.

Single Sideband (1)

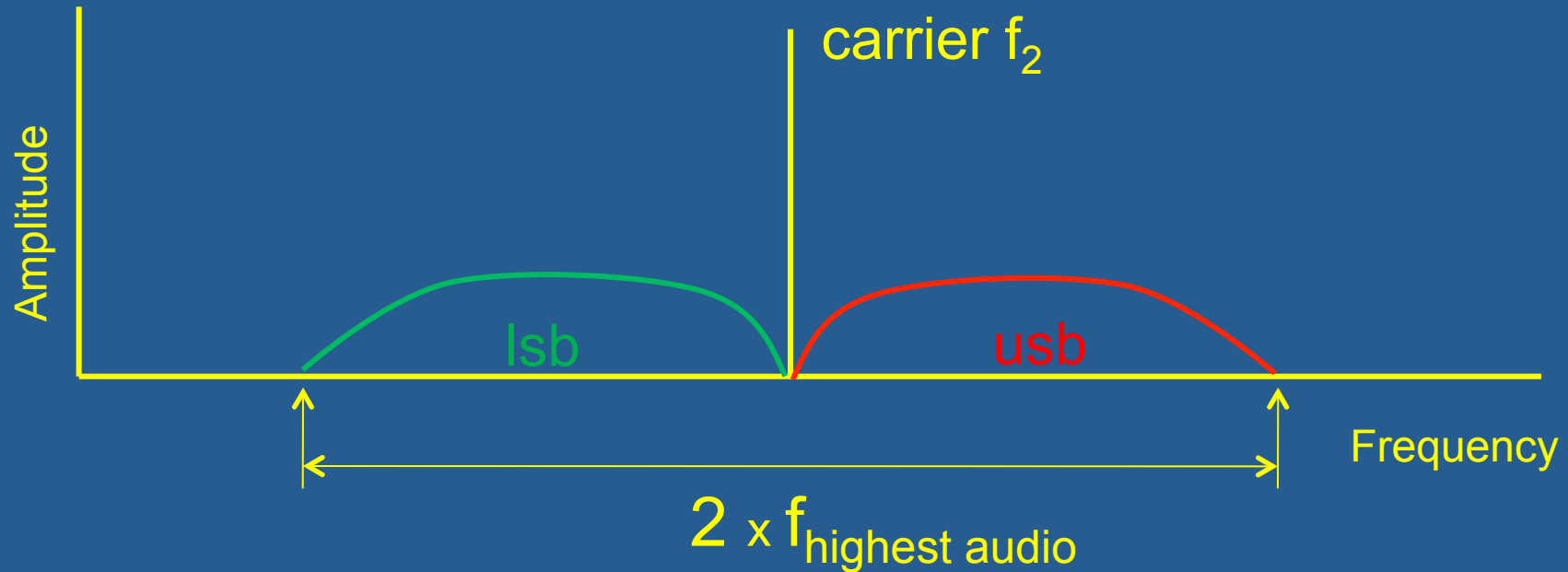

Both sidebands (upper and lower) carry identical information – but each is the mirror image of the other. The carrier wave itself carries no information. Its purpose is to fix the position of the sidebands on the frequency spectrum. If the highest audio frequency is f_h then the AM signal occupies a bandwidth of twice the highest audio frequency.

eg. f_h is 3kHz. The bandwidth (bw) is thus $2 \times 3\text{kHz} = 6\text{kHz}$

Single Sideband (2)

If you suppress one of the sidebands – *it does not matter which one as they both carry the same information* – and the carrier as well then:

- You halve the bandwidth needed for the signal;
- You can use all of the available transmitter power in the sideband.

