

Cambridge and District Amateur Radio Club

1919 – 2006

cdarc.org.uk

President Gordon Mallion G0TZQ

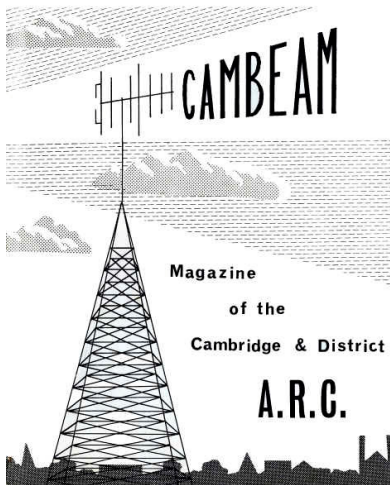

Cambeam – November 2006 Vol.1 No.2

Distributed by: - email (send your address to the editor), or posted to absent members by prior agreement.

Editorial

Welcome to the November issue of Cambeam. Our last issue was distributed by hand at the Club and the remainder by post. To reduce costs the newsletter will now be emailed to as many members as possible. Please keep the Secretary updated with any changes to your email address.

Articles are always welcome and may be emailed to cambeam@g8jkv.co.uk or handed to David G8JKV on a Friday evening.

Chairman's Foreword

At the last committee meeting I proposed that we should re-start the Morse class and my suggestion was unanimously agreed. When I joined the club in the late seventies, a Morse class was already going and well attended. In those days, if you wanted an HF licence you had to be able to send and

receive at twelve words a minute and the exam for the licence was much more difficult than it is today. Wilf Dunell G3BYW was running it and his standards were very high as he was a professional in radio communications.

Before retiring he held very senior positions in the Post Office. His last post was 'Assistant Inspector of Wireless Telegraphy' and 'Head of Maritime Radio Regulations'. Don't forget that it was the Post Office that controlled all wireless communications and broadcasting at that time, so you could not find anyone better than Wilf to run our Morse class. He had been Chairman and then became our President. As the years went by, Wilf became unable to drive so did not attend the club as much. This did not deter him, as he continued to hold a Morse class at his house every Monday evening, to which many of us attended. His wife Betty would provide us with tea, coffee and biscuits and always made us very welcome. It

was always a very nice occasion but sadly came to an end when Wilf died in November 2002. In the meantime, Gordon Mallion G3TZQ had taken over the class and did a wonderful job, but about two years ago, he also became unable to carry on and the Morse class ended.

We all know that the Morse requirement for a licence now is almost non existent, but you only have to listen at the bottom end of any band to hear that it is very much alive. It is a great medium for amateur communications and quite a challenge as I think it needs more courage to go on the air with a key than a microphone. I know there is interest, as Dave and Mike have even developed Morse readers as a club project. Every licensed amateur should really know the code. Let's get the Morse class going again, do come and join in, you may want to learn from the beginning or improve your speed. It is all part of the fun of Amateur Radio.

Ron G3KBR Chairman

Club Notices

Membership.

The Club membership year runs from the 1st of April, so far we have 40 paid up members. If you haven't paid your dues this year please do so. If you are reading this and are not a member please consider joining us.

Social evenings.

We will be holding social evenings on the third Wednesday of the month, usually a pub night. Suggestions for venues, or alternative events are welcomed.

Contest results

PW Contest

Our final adjudicated position was 8th out of 63 and 3rd in the multi operator section. This is an excellent result for the club and our best ever.

RSGB Club Championship

The final results table shows CDARC as 28th out of 72 club entries. Great result for the club. Well done to all whom took part.

The dates for next years Club Championship are: -

February 5th – SSB; 14th – Data; 22nd - CW.
March 5th – Data; 14th – CW; 22nd - SSB.
April 2nd– CW; 11th – SSB; 19th - Data.
May 7th– SSB; 16th – Data; 24th – CW.
June 4th – Data; 13th – CW; 21st– SSB.
July 2nd– CW; 11th – SSB; 19th - Data.

September 144 MHz Trophy Contest

Our final position was 8th out of 16 in the multi operator section of the contest. We lost 16 contacts in the adjudication process amounting to 3.9% of our claimed score.

Considering the weather and the usual crop of technical problems this is an excellent result for the club. If you think we had problems then read some of the other entrant's comments on the VHF Contest web site.

Proposal for a 3cm Cambridge beacon

Within the East of England Region there is no 10 GHz Narrow Band Beacon suitable as a reference source, or for propagation experiments.

Over the last few years this has hampered interested radio amateurs from expanding into this area of the spectrum. Bernie Wright G4HJW has agreed to build such a device and be responsible for the engineering requirement with assistance from C&DARC members.

There have been quite a number of Cambridge amateurs who have operated WBFM on 3cm, but few have gone narrow-band. Part of the reason for this is the lack of a guaranteed local signal source. At a national level, the number of UK 3cm beacons is quite small, so another one would be useful.

Cambridge Repeater Group were approached the by Cambridge and

District Amateur Radio Club to see if a beacon collaboration was of interest, and this proposal stems from that meeting. This proposal was approved at the CRG and C&DARC in 2005.

Site

Madingley is being suggested as a possible site. From a local point of view, Madingley would provide a very strong signal - strong enough for testing quite simple WBFM as well as narrow-band equipment.

Antenna

The waveguide slot antenna used on the defunct wideband beacon, located at Coleridge Road site would be suitable. If any re-matching is necessary, John G4BAO has offered to do this, and would also be prepared to produce a new antenna, if required.

Transmitter

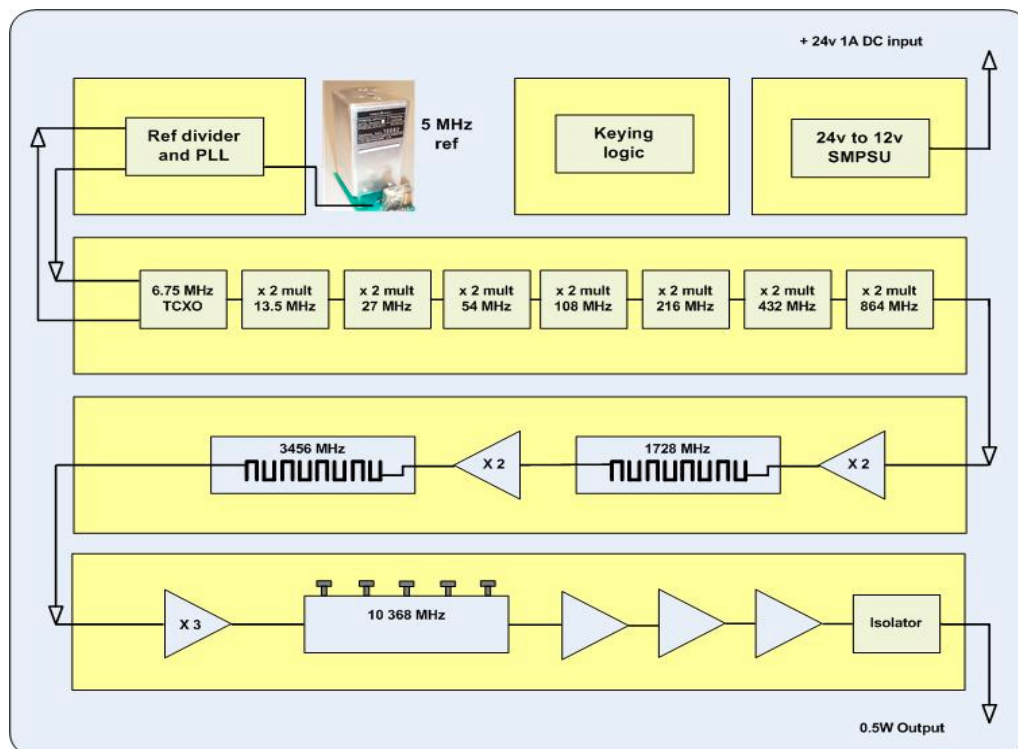

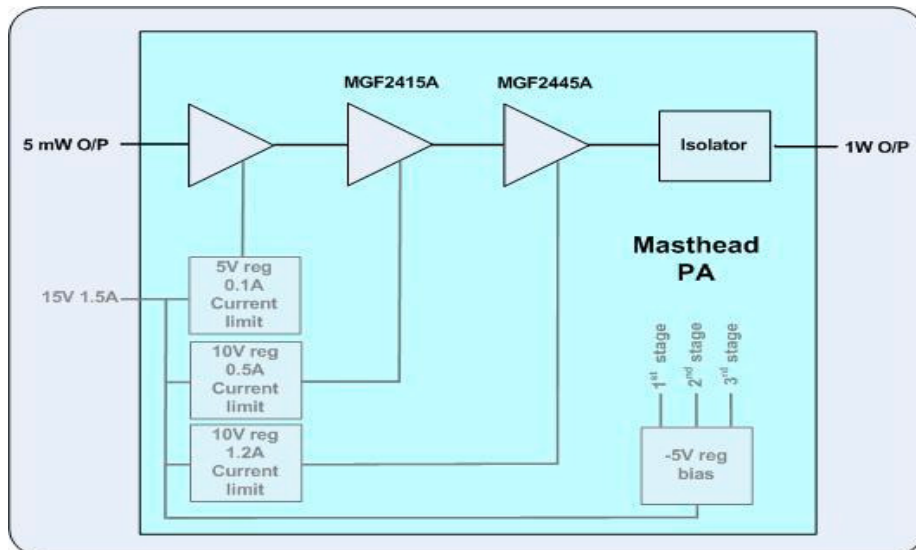

Assuming an amplifier gain of 20dB translates to a maximum feed length of:

RG223	8m
LMR200	17m
LMR400	40m
LDF2-50	45m
LDF4-50	74m

Some UK beacons are wholly mounted at the antenna, so perhaps this also be considered.

The DC supply could be sent up the feed cable along with the RF.

The plan at the moment is to produce about 0.5W at the transmitter and either use this directly to feed the antenna, or if the feed loss is excessive, to drive a masthead power amplifier at 1W output. Isolators would be fitted to the transmitter output and also the antenna mounted PA, if used. A 3U shelf will be used, with the circuitry spread across several (removable) modules. It is intended to run the equipment from 24v DC, with an external AC PSU provided to run from the mains, if needed. The signal will initially be generated at 6.7 MHz, and multiplied to 10 368 MHz via a succession of x2 stages (to 3456 MHz, followed by a x3 multiplier).

Stability from the unovened crystal source is expected to be about +/- 5 KHz over the year, but this will be locked to a Racal 9420 ovened 5 MHz standard, which should improve this to +/- 100 Hz. It might be useful to provide remote fine adjustment to take account of ageing.

The final frequency will be somewhere between 10.368,800 and 10.368,950 MHz, as per the licence allocation,

Logic

Andrew Burge M0BXT has offered to design the callsign keyer for this beacon and has already contacted Bernie with some ideas. Station keying will be 400 - 1k Hz FSK, and need only consist of the callsign repeated at 15-second intervals.

We like to take this opportunity to thank all the microwave enthusiasts in the area for their support with this project.

Bernie Wright G4HJW and Mike Newport G8VCN 27th Nov 2006.
<http://www.g4hjwt.metahusky.net>

A SIMPLE (SES) SOLAR FLARE DETECTOR USING VLF

1. This short article and accompanying diagrams describes how to construct a simple, sudden

enhancement of signal (SES) solar flare detector. The detector monitors sudden changes in signal strength from a distant VLF station caused by enhancement of the D layer in the ionosphere following a solar flare. The cost of the detector is about £5 and a lot of the parts may be sourced from the junk-box.

BASIC BLOCK SCHEMATIC FOR SES SOLAR FLARE DETECTOR

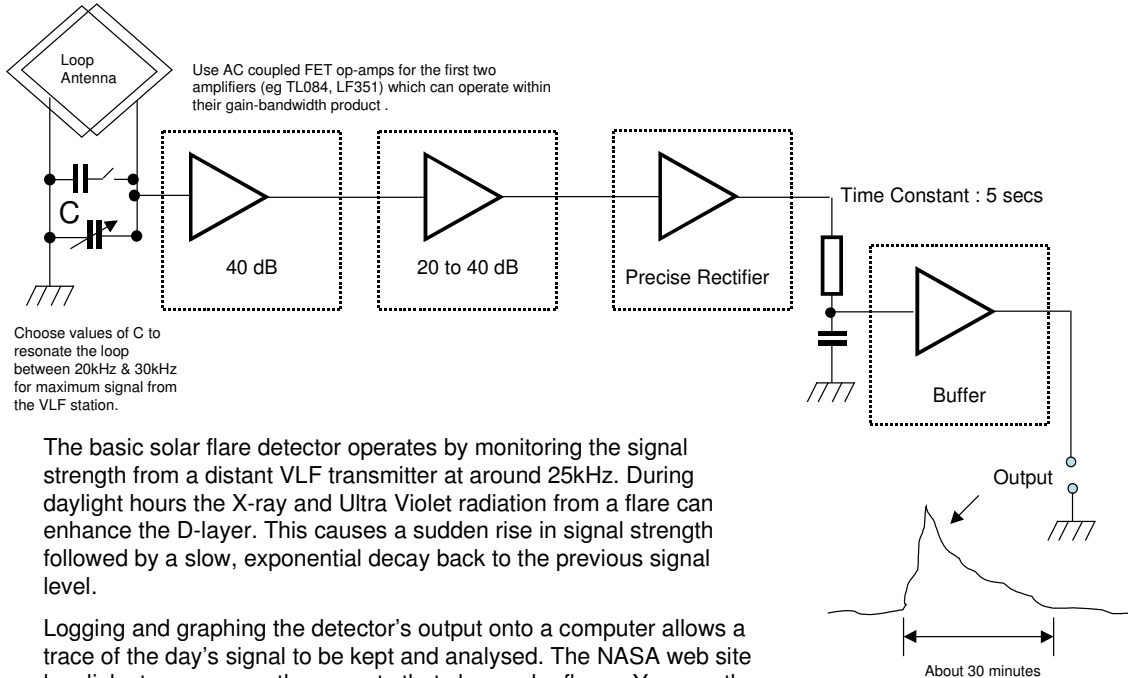

The basic solar flare detector operates by monitoring the signal strength from a distant VLF transmitter at around 25kHz. During daylight hours the X-ray and Ultra Violet radiation from a flare can enhance the D-layer. This causes a sudden rise in signal strength followed by a slow, exponential decay back to the previous signal level.

Logging and graphing the detector's output onto a computer allows a trace of the day's signal to be kept and analysed. The NASA web site has links to space-weather reports that show solar flares. You can then easily correlate the detector trace with the satellite report.

Typical Solar Flare Trace. (Signal Strength)

2. **Flares:** A solar flare is a brightening of an area of the solar disc and is associated with sunspots. Flares are probably powered by the collapse of magnetic fields between a pair of sunspots. They liberate significant amounts of energy in the ultra-violet and X-ray part of the spectrum. Flares have noticeable effects on radio propagation. On reaching the Earth the energy can enhance the D-layer above the daytime hemisphere. The signal strength from a distant VLF transmitter (generally between 20kHz and 30 kHz) will show a steep, characteristic increase followed by a

slow decay over the following 30 minutes under flare conditions. Flares do not seem to generate these increases above 70 kHz. There is a strong French VLF station which transmits almost continuously on 21.75 kHz. This is far enough away for D-layer enhancements to have a measurable effect on the received signal strength in Cambridge.

3. **The Loop Antenna:** The loop antenna used in the detector is easy to build. Four pieces of 10mm dowel each about 300mm long are glued into holes in a small 50mm square block of wood to form a cross. A Vee

notch in the end of each arm contains the wire turns. You will need to wind about 120 turns of 26 swg enamelled copper wire to form the loop.

4. The resulting loop will have an inductance of approximately 22 mH, a resistance of 35 ohms and be self resonant around 35 kHz. (ie you can't resonate the loop any higher in frequency than this.) This implies a theoretical inter-winding capacitance of about 940 pF. A suitable combination of switched capacitors, eg 220 pF, 330 pF, 1000 pF and 2000 pF in parallel with a 500 pF variable capacitor across the windings will allow you to resonate the loop continuously between 20 kHz and 30 kHz. You need to add about 1900 pF to resonate at 20 kHz and 330 pF to resonate at 30 kHz). You can devise a simple mounting system to allow the loop to stand vertically and be rotated to produce the maximum signal.

5. **The Amplifiers:** To get a useful output you will need to have about 60dB to 80dB of voltage gain. Simple op-amps are fine but be aware of the amplifier's gain-bandwidth product. (Unity gain bandwidth) For example: If the op-amp gain-bandwidth product is 1,000,000 then if you operate the amplifier at around 25 kHz you can only have an output gain of 40 times. (40 x 25,000 = 1,000,000). Be prepared to experiment a bit with this part of the detector. Making one of the amplifiers with a variable gain will help find a practical operating point. I used LF351 FET op-amps with a 4MHz gain-bandwidth product. Inverting or non-inverting configurations are equally good – but don't load the loop antenna too much when you attach the first stage of amplification. Use AC-coupled amplifiers.

Non-Inverting x100 AC Amplifier (40 dB Gain)

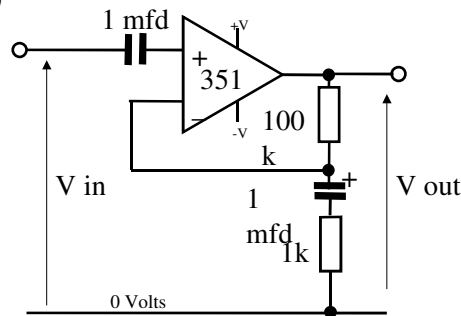

$$V_{out} = V_{in} \times \frac{100+1}{1}$$

6. **The Precise Rectifier:** This is a rectifier where the forward voltage drop of the diode is divided by the open loop gain of the amplifier. This virtually eliminates the voltage drop

and allows the diode to linearly rectify very small signals. A couple of germanium signal diodes and a 741 op-amp work well. (It's all DC after this point.)

Precise Rectifier

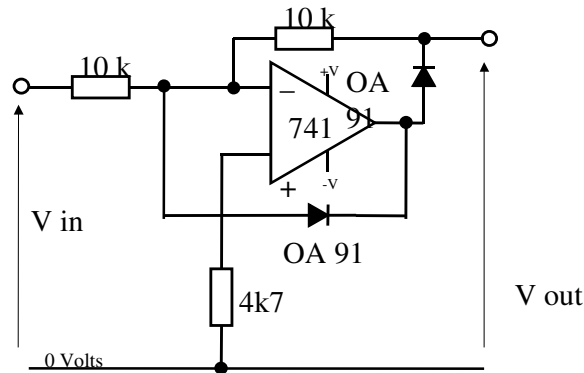

7. Time Constant: The rectifier operates into a simple RC time constant circuit which takes out any big, short duration fluctuations. Some switched capacitors here will allow you to experiment with different time constants. A five second time constant is a good place to start. (eg 10 mfd and 470 k). There are lots of circuits you can add at this point to do some signal processing. (Peak detector, sample and hold, differential amplifier, etc.) You might need to add a DC amplifier to raise the signal level before processing further.

8. Buffer: To avoid loading the time constant circuit you should use a buffer (unity gain follower) before you connect to the recording device. Again a 741 will work well here.

9. Recording: I use a DOS-driven, old 286 computer running GW Basic as the recording device. A simple home-made ADC is attached to the detector output and sends 8-bit data once each minute to the BASIC program. The data is read 4 bits at a

time via the parallel printer port. A one-pixel wide line (the height of which is proportional to the detector output voltage) is plotted every minute on the screen. This gives about 10 hours of logging at the screen resolution I use. (Crude but it works!). No doubt there are better, purpose-built logging programs for "whizzier computers".

10. Next Solar Cycle: We are now coming out of a sunspot minimum in Cycle 23. Cycle 24 will probably start in 2007. (They run from minimum to minimum but gauging the exact minimum is not straightforward.) In the run up to the next solar sunspot maximum this is an interesting little project to monitor events on our own star. It also provides an insight into the diurnal changes in the D-layer and VLF propagation. There are a number of articles on the web. A search for solar cycle, solar flare, solar flare detector will produce some good links. Another very informative site is the American Association of Variable Star Observers (AAVSO).

144 MHz Trophy contest 2006

This weather at this year's Trophy was so different, very high winds with gusts measured in Cambridge at well over 50 knots. It must have been higher on top of "our" hill. Along with rain and our usual crop of equipment troubles it was hard going at times. The operating tent had extra lashing ropes and we used the trailer to offer some shelter as well as the hedge.



Several of the usual visitors from further away were unable to make it, but Daniel and Elisabeth did. Nick and family turned up after the end of the contest, nice to see you Nick but next year please come earlier, we need you.



We did very well compared to many groups and managed to operate for most of the 24 hours. Read the comments on the VHF contest committee claimed scores site to see how bad it could have been! It looks

like we are 8th in the multi operator section of the contest.

<http://www.vhfcc.org/index.html>

A big thank you to those who made this happen.



Dates for your Diary

C&DARC Rally.

Sunday 4th March 2007, at the Britten Arena at Wood Green Animal shelter.

Constructors Contest.

The constructor's contest takes place on February 23rd 2007. All entries are welcome, kit built, or homebrew. Now is the time to plan your project for the contest, or brush the dust off the one under the bench that never got finished!

AGM.

The Annual General Meeting takes place at 8pm on Friday 23rd March 2007.

Web site

The club web site now includes an auto updating section for social events.

Please visit the site regularly to check the programme, social events, and the For Sale / Wanted adverts. Send your adverts to webmaster@metermana.co.uk

Club Projects

Epiphyte MKIV?

David Adshead is redesigning the Epiphyte MKIII to replace the obsolete CA3020 in the transmitter driver section. Frequency stability will be improved with a digitally controlled VFO complete with LCD display. Other modifications include a series of switched AF SSB and CW filters.

Should you be interested in building this project please add your name to the list on the club notice board. This does not commit you at this time!

The Committee for 2006

Due to other commitments Roy Henson M1GRT resigned as secretary at the end of October. I am certain that all members will join the committee in thanking him for his commitment during his period of office.

David Leary takes over as secretary until the AGM.

Chairman Ron Huntsman G3KBR
Secretary David Leary G8JKV
Treasurer John Bonner G0GKP
Programme Co-ordinator Ian Alexander G4AKD

Ordinary member Steve Norman M3MVB
Ordinary Member Mike Addlesee M0BLP
Ordinary member Roy Henson M1GRT
Ordinary member Peter Howell M0DCV

Non Committee Posts

Contest manager David King G6KWA
Newsletter editor Peter Howell M0DCV
Webmaster David Leary G8JKV

For Sale / Wanted

For sale The Club has some equipment that is surplus to requirements. It is intended to replace some of the test equipment with more up to date, lighter items, should enough capital be raised.

Some equipment has already been sold by sealed bid to Club Members. The remainder is offered to all comers at the following prices.

All equipment is sold as seen.

Receivers

Lowe HF225 general coverage receiver and keypad £200.00

Transceivers

FT221 2 meter multi mode (standard front end) £150.00

Accessories

Hi Mound key £30.00

Test Equipment

CT 53 Signal generator (large and heavy) £10.00

TF791D Carrier deviation meter (large and heavy) £15.00

Telequipment D54 two channel oscilloscope (no probes) £20.00

Solatron two channel scope (no probes) £15.00

Books

RSGB handbook (old) £3.00

Tools

Red drill and stand £5.00

B&D H264 drill £3.00

Jigsaw £3.00

Cable roller £50

For sale 5 Band Vertical Hustler Antenna, good condition £75.
Roger, G7IAY 01223 242646

For sale Yaesu VX5R Tri Band Handie. £100 **Reduced!**
Contact Mark, M1MPW on 07980092275 or email bigfathairybiker@hotmail.com

C&DARC Programme

Enquiries and/or suggestions for talks are always welcomed and should be directed to the Programme Co-ordinator Ian Alexander, G4AKD.

December 8th:	Informal
15th:	Mince pie evening!
22nd:	No meeting, College closed
29th:	No meeting, College closed
January 5th 2007:	Informal
12th:	"Kitchen table" minimalist radio (how to have fun for next to nothing) - Roger G3XBM
19th:	Informal
26th:	Scanning Electron Microscope - David G8JKV
February 2nd:	Informal
9th:	Q&A Evening
16th:	Informal
23rd:	Constructors Contest
March 2nd:	Preparation for Rally
4th:	C&DARC Rally at Wood Green
9th:	Quiz Evening
16th:	Informal
23rd:	Annual General Meeting - 8pm (posted 13/05/06)
30th:	Informal
April 6th	No meeting, College closed